

AGENDA

Oakland-Macomb Interceptor Drain Drainage Board Macomb and Oakland Counties

December 17, 2025 – 11:30 a.m.

Office of the Macomb County Public Works Commissioner
21777 Dunham Road, Clinton Township, Michigan, and Microsoft Teams

1. Call meeting to order

Board Members:

Joe Brezvai, Chair, Michigan Department of Agriculture and Rural Development

Candice Miller, Macomb County Public Works Commissioner

Jim Nash, Oakland County Water Resources Commissioner

2. Motion to approve the meeting agenda for December 17, 2025
3. Motion to approve the Drainage District Board Meeting Minutes from November 20, 2025
4. Public Comment
5. Present Memorandum requesting the Board approve Engineering Work Order to extend the contract one year to December 31, 2026
 - a) Motion to approve Engineering Work Order D-496 for amendment to Contract #WDCON8173 to extend contract expiration date to complete previously approved NI-EA and NESPS related tasks
6. Present Memorandum requesting the Board approve Engineering Work Order to extend MCET's Contract to December 31, 2027, and updating MCET's rates
 - a) Motion to approve Engineering Work Order D495 (4) for amendment to Contract #WDCON8419 for instrumentation and control support
7. Motion to approve the following Construction Estimates:
 - a) Construction Estimate No. 13 for Commercial Contracting Corporation for the Odor and Corrosion Control Systems in the amount of \$1,455,290.35
 - b) Construction Estimate No. 9 for Z Contractors, Inc. for Construction of the NI-EA OMID Contract 2-B Only in the amount of \$32,579.09 with a transfer to the Oakland County Treasurer in the amount of \$3,619.90
8. Status of OMID Repairs Project
9. Financial Reports – General Financial Report and Status of State Revolving Fund Financing and Other Financing
10. Motion to approve the following invoices:
 - 1) Labor/Fringes/Non-Direct Labor Factor
 - Segment 5 NI-EA Construction \$ 296.48

	• Segment 5 NESPS Mech./Elect. Construction		\$	9,164.26
	• NIEA Contract #2 Construction		\$	8,021.88
	• Odor/Corrosion System Construction		\$	14,777.85
2)	Equipment Charges			
	• Segment 5 NI-EA Construction		\$	11.96
	• Segment 5 NESPS Mech./Elect. Construction		\$	266.45
	• NIEA Contract #2 Construction		\$	161.93
	• Odor/Corrosion System Construction		\$	1,162.14
a)	ASI			
	Invoice No. 9453	NESPS	\$	76,800.93
b)	Clark Hill			
	1) Invoice No. 1648638	NESPS	\$	2,135.00
	2) Invoice No. 1657174	NESPS	\$	3,710.00
c)	CSM Mechanical			
	Invoice No. 6092	O&M	\$	470.00
d)	Hesco			
	Invoice No. 2019807-003	O&M	\$	571.94
e)	Jacobs			
	Invoice No. C6A19900-31	O&C	\$	53,478.48
f)	Kennedy			
	Invoice No. 647319 b	O&M	\$	4,781.38
g)	Lardner Elevator			
	1) Invoice No. 205990	O&M	\$	14,998.00
	2) Invoice No. 206473	O&M	\$	214.00
	3) Invoice No. 206799	O&M	\$	214.00
h)	Metco-			
	Invoice No. 1811-83	O&M	\$	92,567.51
i)	Motor City			
	1) Invoice No. 96914	O&M	\$	317.50
j)	NTH			
	1) Eng./Consult. Services OMID PCI-18 & PCI-19 Rehab			
	Invoice No. 640770	NI-EA	\$	69,284.01
	2) Project Closeout 2021/Discharge Chamber CCA			
	Invoice No. 640766	O&M	\$	805.15
k)	PMA			
	1) Invoice No. 03559.01-63	NESPS	\$	14,853.10
	2) Invoice No. 03559.01-65	NESPS	\$	17,436.25
l)	PM Technologies			
	1) Invoice No. 130373457	O&M	\$	350.00
	2) Invoice No. 130380504	O&M	\$	350.00
	3) Invoice No. 130380529	O&M	\$	350.00
m)	Rotor Electric			
	1) Invoice No. 12946	O&M	\$	4,503.00
	2) Invoice No. 12947	O&M	\$	2,013.00
	3) Invoice No. 12948	O&M	\$	2,013.00
	4) Invoice No. 12949	O&M	\$	1,006.50
	5) Invoice No. 12950	O&M	\$	1,342.00
n)	Walsh Construction II			
	Invoice No. 220008-970500	NESPS	\$	2,137,215.50

11. Other Business

12. Adjourn

Next Regular Meeting: January 21, 2026, at 11:30 a.m., Eastern Standard Time.

Agenda Item No. 3

Board Meeting Minutes from November 20, 2025

**MINUTES OF THE REGULAR MEETING OF THE DRAINAGE BOARD
FOR THE OAKLAND-MACOMB INTERCEPTOR DRAIN DRAINAGE DISTRICT**

November 20, 2025

Minutes of the regular meeting of the Drainage Board of the Oakland-Macomb Interceptor Drain Drainage District held at the office of the Macomb County Public Works Commissioner, 21777 Dunham Road, Clinton Township Michigan on the 20th day of November 2025 at 10:30 a.m. Eastern Standard Time and via Microsoft Teams.

PRESENT:

Joe Brezvai, Chairperson and Deputy for Dr. Tim Boring, Director of the Michigan Department of Agriculture and Rural Development; Candice Miller, Member and Macomb County Public Works Commissioner; and Jim Nash, Secretary and Oakland County Water Resources Commissioner.

OTHERS PRESENT:

Representing the office of the Macomb County Public Works Commissioner; Brian Baker, Don Brown, Steven Downing and John Caron. Representing the office of the Oakland County Water Resources Commissioner: Steve Korth, Anne Vaara, Kelsey Cooke, Sara Rubino, Brian Coburn, Trisha Bruzek, Joel Brown, Jen Cook, Alyssa Taube, Claudia Luckenbach-Boman and Mel Todd. Others in attendance: Shawn Phelps and Heidi Grunwald (OC Fiscal Services), Fritz Klingler (FK Engineering Associates), Jessica Johnston (City of Sterling Heights), Brandon Williams (MDARD) and Terry Moore (Metco).

1. Call meeting to order.

Chairperson Brezvai called the meeting to order at 11:30 a.m.

2. Agenda.

Motion by Miller, supported by Nash, to approve the November 20, 2025, agenda as presented.

ADOPTED: Yeas - 3
 Nays - 0

3. Minutes.

Motion by Nash, supported by Miller, to approve the minutes of the October 15, 2025, meeting.

ADOPTED: Yeas - 3
 Nays - 0

4. Public Comment.

None.

5. Memorandum regarding METCO Engineering Work Order for Contract # WDCON8448 to Extend Operation, Maintenance, and Management of NESPS, OMID and NI-EA System Infrastructure through 2028

a) Joel Brown shared the current contract with METCO is set to expire at the end of 2025. With the continued need to provide operational and maintenance related services for OMID infrastructure in the future, Mr. Brown reviewed METCO's proposed annual budget(s) for services provided through 2028. Mr. Brown stated METCO has been outstanding at providing services over the past six years and reviewed Engineering Work Order (D-493-3) that was

developed for continued use of METCO's services based on their appended proposal dated November 6, 2025.

Motion by Miller, supported by Nash, to approve the Engineering Work Order (D-493-3) for Metco to provide continued operations and maintenance services for the NESPS, OMID and NIEA for a not-to-exceed amount of \$2,846,110.52 as presented.

ADOPTED: Yeas - 3
Nays - 0

6. Memorandum regarding METCO Engineering Work Order Amendment to Contract # WDCON8448 for Engineering Design Services of the NESPS Pump 2

- a) Joel Brown advised the variable frequency drive (VFD) system for the NESPS Pump No. 2 was installed in 2005 and has been experiencing frequent outages due to failures of electrical components, many of which have become difficult to address as the parts are now obsolete. As the overall reliability of the pump significantly declines, Metco was asked to generate a proposal to provide design and bidding services for procurement and installation of a new VFD as detailed in Engineering Work Order (D-494-4).
- b) Joel Brown reviewed the NESPS Pump 2 VFD Replacement (Design/Procurement) Estimate of Total Project Costs Form stating the total project cost of \$1,500,000.00

Motion by Miller, supported by Nash, to approve the Engineering Work Order to initiate the design of the Pump No. 2 VFD Replacement using METCO's existing contract #WDCON8448 and increase the contract amount by \$299,244.00 and authorize the establishment of a Project with a current budget of \$1,500,000.00 to track design related expenses for the work as presented.

ADOPTED: Yeas - 3
Nays - 0

7. Construction Pay Estimates.

The following Construction Pay Estimates were submitted to the Board for approval:

- a) Construction Estimate No. 12 for Commercial Contracting Corporation for the Odor and Corrosion Control Systems in the amount of \$544,232.64. Motion by Miller, supported by Nash, to approve Construction Estimate No. 12 as presented.

ADOPTED: Yeas - 3
Nays - 0

- b) Construction Estimate No. 8 for Z Contractors, Inc. for Construction of the NI-EA OMID Contract 2-B Only in the amount of \$240,983.81 with a transfer to the Oakland County Treasurer in the amount of \$26,775.97. Motion by Miller, supported by Nash, to approve Construction Estimate No. 8 as presented.

ADOPTED: Yeas - 3
Nays - 0

8. Report/Update – Status of OMI Project, Segments 1 through 4, NESPS and NI-EA.

Fritz Klingler summarized progress updates for various rehab projects within OMIDDD. Motion

by Miller, supported by Nash, to receive and file the report as presented.

ADOPTED: Yeas - 3
Nays - 0

9. Financial Reports.

Motion by Nash, supported by Miller, to receive and file the financial reports as received.

ADOPTED: Yeas - 3
Nays - 0

10. Invoices.

1) Labor/Fringes/Non-Direct Labor Factor			
• Segment 5 NI-EA Construction		\$	793.60
• Segment 5 NESPS Mech./Elect. Construction		\$	8,586.29
• NIEA Contract #2 Construction		\$	13,023.40
• Odor/Corrosion System Construction		\$	22,524.20
2) Equipment Charges			
• Segment 5 NI-EA Construction		\$	35.88
• Segment 5 NESPS Mech./Elect. Construction		\$	333.57
• NIEA Contract #2 Construction		\$	294.60
• Odor/Corrosion System Construction		\$	2,007.61
a) CSM Mechanical			
1) Invoice No. 5669	O&M	\$	9,968.79
2) Invoice No. 5725	O&M	\$	1,357.31
b) Done Right Signs			
1) Invoice No. 23610*	O&M	\$	2,875.72
2) Invoice No. 23613*	O&M	\$	3,720.00
c) Dunbar			
1) Invoice No. 10012174	O&M	\$	9,771.00
2) Invoice No. 10013841	O&M	\$	355.00
d) Hesco			
1) Invoice No. 242989	O&M	\$	8,665.00
2) Invoice No. 2019807-001	O&M	\$	11,789.10
3) Invoice No. 2019807-002	O&M	\$	5,549.33
e) Jacobs			
Invoice No. C6A19900-30	O&C	\$	66,752.79
f) Kennedy			
Invoice No. 647170	O&M	\$	918.50
g) Lardner Elevator			
Invoice No. 206187	O&M	\$	214.00
h) Maple Press			
Invoice No. 161450	O&M	\$	235.00
i) Metco-			
Invoice No. 1811-82	O&M	\$	89,263.96
j) Motor City			
1) Invoice No. 96839	O&M	\$	95.25
2) Invoice No. 96803	O&M	\$	147.00
k) NTH			

1)	Eng./Consult. Services OMID PCI-18 & PCI-19 Rehab			
	Invoice No. 640520	NI-EA	\$	70,568.96
2)	Consulting Services 2021 OMID System Inspection			
	Invoice No. 640519	O&M	\$	304.37
l)	PMA			
	Invoice No. 03559.01-64	NESPS	\$	12,269.95
m)	PM Technologies			
	1) Invoice No. 124141041	O&M	\$	350.00
	2) Invoice No. 124149166	O&M	\$	350.00
	3) Invoice No. 124150890	O&M	\$	350.00
n)	Rotor Electric			
	1) Invoice No. 12927	O&M	\$	10,453.21
	2) Invoice No. 12929	O&M	\$	32,420.83

Motion by Miller, supported by Nash, to approve the invoices as presented.

ADOPTED: Yeas - 3
Nays - 0

11. Other Business.

None.

12. Adjourn.

Motion by Nash, supported by Miller, to adjourn the November 20, 2025, meeting at 12:13 p.m.

ADOPTED: Yeas - 3
Nays - 0

Next Regular Meeting *Office of the Macomb County Public Works Commissioner, 21777 Dunham Road, Clinton Township, Michigan* and electronically at 11:30 a.m., Eastern Standard Time on December 17, 2025.

I hereby certify that the foregoing constitutes the minutes of the Drainage Board for the Oakland-Macomb Interceptor Drain Drainage District, at a meeting held on November 20, 2025, and that the meeting was conducted and public notice was given in compliance with the Open Meetings Act being Act 267, Public Acts of Michigan, 1976, as amended, and that the minutes were kept and will be or have been made available to the public as required by the Act.

IN WITNESS WHEREOF, I have hereunto affixed my official signature on this 20th day of November 2025.

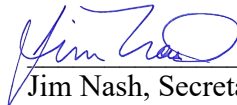

Jim Nash, Secretary

Oakland-Macomb Interceptor Drain Drainage Board

Agenda Item No. 4

Public Comment

Agenda Item No. 5

Memorandum to Approve Engineering Work Order
D-496



Oakland-Macomb Interceptor Drain Drainage District

**TO: Joseph Brezvai, Chairperson,
Oakland-Macomb Interceptor Drain Drainage Board**

**FROM: Joel Brown, P.E., Oakland County Water Resources Commissioner's Office
Stephen Downing, P.E., Macomb County Public Works Commissioner's Office**

**SUBJECT: Time Extension to Fulfill Existing North Interceptor – East Arm and
Northeast Sewage Pump Station Scope of Work**

DATE: December 17, 2025

Contract #WDCON8173, previously awarded to NTH Consultants, Ltd., is scheduled to expire on December 31, 2025. This contract cannot be extended without Board approval.

NTH Consultants currently has several active assignments that will extend beyond the existing contract term, including:

- Northeast Sewage Pumping Station Operations and Maintenance Spill Control Prevention Plan work under Engineering Work Order (EWO) #D-488.
- Significant remaining construction contract administration for the North Interceptor – East Arm (NI-EA) Contract 2B under EWO #D-458.
- Additional work associated with the NI-EA Pilot Study authorized under EWO #3 dated June 18, 2025.

These efforts are expected to continue through late 2026. To ensure uninterrupted progress and completion of Board-authorized work, it is necessary to extend Contract #WDCON8173 by approximately one year to December 31, 2026.

Attached for your review is EWO #D-496, which provides for this one-year extension to allow NTH Consultants to complete all currently authorized assignments.

Requested Action: Approve the attached Engineering Work Order (EWO #D-496) extending Contract #WDCON8173 through December 31, 2026.

**Jim Nash Oakland County Water Resources Commissioner
Oakland-Macomb Interceptor Drain Drainage District
For the
OMID NESPS Maintenance Engineering Support Services-SPCC and PIPP Updates
Wayne County, Michigan**

Engineering Work Order D-496

Date: 12/9/2025

To: NTH Consultants Ltd. (NTH)

For: Amendment to Contract #WDCON8173 To Extend Contract Expiration Date to Complete Previously Approved NI-EA and NESPS Related Tasks

DESCRIPTION

This Engineering Work Order (EWO) is required to provide additional time compensation related to existing NI-EA and NESPS work scope that falls under Section A-Engineering Services and Section C Compensation for Engineering Services, Item No. 6 Additional Special Services and Exhibit D – Estimated Fees of contract #WDCON8173. This EWO serves as your approval for time compensation to complete the following previously approved engineering services needed at the NESPS and NI-EA (and others as required).

- Northeast Sewage Pumping Station (NESPS) Operations and Maintenance Spill Control Prevention Plan work under EWO # D-488.
- Construction contract administration left on the NI-EA Contract 2B under EWO# D-458
- NI-EA Pilot Study work to perform (EWO#3 dated 6/18/2025)

Fees for this Engineering Work Order shall continue to be billed on a time and material basis. The total amount of the Contract remains unchanged. The Contract shall be extended one year until December 31, 2026.

RECOMMENDED	DATE: 12/10/2025	ACCEPTED	DATE:
By: 		By:	
Joel Brown, P.E. Chief Engineer OCWRC		Jeff Jaros, P.E. President NTH Consultants Ltd.	
APPROVED	DATE:	APPROVED	DATE:
By:		By:	
Stephen Downing Construction and Maintenance Manager MCPWO		Steve Korth, P.E. Chief Manager OCWRC	
Approved by the Drainage District Board on:			

**JIM NASH
OAKLAND COUNTY WATER RESOURCES COMMISSIONER**

Department No.:	6010101	Account No.:	SC730639
Fund No:	FND82912	Program No.:	PRG149090
Project No:	N/A	Project Activity:	N/A
Contract No:	PS2603-WDCON8173	Contract Exp:	12/31/2026

Agenda Item No. 6

Memorandum to Approve Engineering Work Order
D-495 (4)



Oakland-Macomb Interceptor Drain Drainage District

**TO: Joseph Brezvai, Chairperson
Oakland-Macomb Interceptor Drain Drainage Board**

**FROM: Joel Brown, P.E., Oakland County Water Resources Commissioner's Office
Stephen Downing, P.E., Macomb County Public Works Commissioner's Office**

SUBJECT: Motor City Electric Technologies Engineering Work Order to Extend Contract #WDCON8419 and Adjust Rate Compensation

DATE: December 17, 2025

The existing contract #WDCON8419 between the Oakland-Macomb Interceptor Drain Drainage District and Motor City Electric Technologies (MCET) is scheduled to expire on December 31, 2025. The Board previously approved an extension on November 13, 2023. The contract has been used primarily for MCET to provide as-needed Systems Control and Data Acquisition (SCADA) troubleshooting, repair, programming, and related services for the Northeast Sewage Pumping Station (NESPS) and the Oakland-Macomb Interceptor Drain control structures. MCET personnel continue to deliver knowledgeable, reliable, efficient and cost-effective support.

The contract was originally intended to conclude upon completion of the NESPS and North Interceptor – East Arm (NI-EA) capital projects. However, the NI-EA Contract 2 project remains ongoing with rehabilitation of the existing control structures scheduled for 2026 and 2027. MCET continues to play a vital role in maintaining OMID system functionality and SCADA operations necessary for flow-control management. Therefore, it is recommended that Contract #WDCON8419 be extended through December 31, 2027 to ensure continuity of these critical services until the control structure work is complete.

An Engineering Work Order (attached) has been prepared to update compensation rates with MCET's current rate schedule and to extend the contract term to December 31, 2027. No contract price increase is required at this time because there are sufficient funds remain available under the existing contract.

RECOMMENDED ACTION: Approve the attached Engineering Work Order extending MCET's Contract #WDCON8419 to December 31, 2027 and updating MCET's rates.

**Jim Nash Oakland County Water Resources Commissioner
Oakland-Macomb Interceptor Drain Drainage District
For the
OMIDDD Operations and Maintenance I&C Services
Oakland, Macomb and Wayne County, Michigan**

Engineering Work Order D-495 (4)

Date: 12/8/2025

To: Motor City Electric Technologies Inc. (MCET)**For:** Amendment to Contract #WDCON8419 to Extend Contract Expiration Date and Rates for Instrumentation and Control Support**DESCRIPTION**

This Engineering Work Order (EWO) is required to define specific additional tasks and compensation related to OMID Systems Control and Data Acquisition (SCADA) functionality that falls under Section 3-Scope of Contractor's Services, Section 4, Drainage District Payment Obligation for Contractor's Services, Exhibit II - Scope of Contractor's Services and Exhibit III - Contractor's Proposal of contract #5469(WDCON8419). This EWO serves as your approval for the following additional general services.

Extend Contract #WDCON8419 two years until December 31, 2027 to continue to provide services contained in the original contract and subsequent Engineering Work Orders. Work shall be billed on a time and material basis according to the attached 2026-2027 rate sheet. No additional contract amount increase is needed currently.

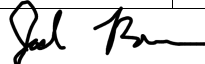
RECOMMENDED	DATE: 12/10/2025	ACCEPTED	DATE:
By: 		By:	
Joel Brown, P.E. Chief Engineer OCWRC		Dave Volkman President Motor City Electric Technologies, Inc.	
APPROVED	DATE:	APPROVED	DATE:
By:		By:	
Stephen Downing Construction and Maintenance Manager MCPWO		Steve Korth, P.E. Chief Manager OCWRC	
Approved by the Drainage District Board on:			

Department No.:	6010101	Account No.:	SC730660
Fund No.:	FND82912	Program No.:	PRG149090
Project No.:	N/A	Project Activity:	N/A
Contract No.:	PS5469-WDCON8419	Contract Exp:	12/31/2027

**JIM NASH
OAKLAND COUNTY WATER RESOURCES COMMISSIONER**



Motor City Electric Technologies, Inc.

9440 Grinnell St.
Detroit, MI 48213-1151
(313) 921-5300 Phone
(313) 921-5310 Fax
www.mceco.com

Registered to ISO 9001:2015

Schedule of Service Rates

Valid through October 1, 2027

SCHEDULED

	Standard	Overtime	Premium
• Engineer - Instrumentation Calibration Technician	125.00	163.00	213.00
• Engineer - Controls / PLC / SCADA / Automation	127.00	165.00	216.00
• Engineer - Wireless / RF / Network	132.00	185.00	185.00
• Project Manager	128.00	168.00	212.00
• Technician - Voice / Data / Security / Wireless	89.00	120.00	153.00
○ <i>Elevated/Tower work, 60' = +15% Premium</i>			
○ <i>2nd Shift = +10% Premium, 7.5 Hours for 8 Hours</i>			
○ <i>3rd Shift = +15% Premium, 7 Hours for 8 Hours</i>			

EMERGENCY (24/7, 4-Hour Response, 4-Hour Minimum)

• Engineer - Controls / PLC / SCADA / Automation	191.00	258.00	325.00
• Engineer - Wireless / RF / Network	191.00	258.00	325.00
• Technician - Voice / Data / Security / Wireless	180.00	243.00	306.00

TRAVEL

• Site to Site (Scheduled)	Scheduled Rates Per Above		
• Site to Site (Emergency)	Emergency Rates Per Above		
<i>Outside Greater Detroit, Tri-County Area</i>			
• Company or Personal Car	Current IRS Rate Plus 15%		
• Parking, car rental, airfare, public transportation, tolls, and lodging	Cost		
• Meals	\$45 Per Day		

EQUIPMENT

• Service Truck / Van	\$9.50 Per Hour		
-----------------------	-----------------	--	--

MATERIAL

• Material	Cost Plus 15%		
------------	---------------	--	--

Description of Rates

Standard Rate:	Monday through Friday, 8 consecutive hours, between the hours of 7:00 a.m. and 5:00 p.m.
Overtime Rate:	Monday through Friday, in excess of 8 hours per day, Saturdays, and Monday through Friday between the hours of 5:00 p.m. and 7:00 a.m.
Premium Rate:	Sundays and holidays

TERMS & CONDITIONS

A purchase order is required before work is performed. One meal per day will be added for each overnight stay. The minimum billing within the USA is 4 hours of labor. The minimum billing for locations outside of the USA is 5 days of labor plus travel and living expenses. Unless otherwise noted, fees are hourly and billed in 0.25 hour increments. Payment terms are net 30 days from invoice date. Labor and travel time will be recorded on a daily time log or field report. This Schedule of Rates is subject to change July 1 of every year.

Agenda Item No. 7

Construction Estimates

CONSTRUCTION ESTIMATE

[Empty rectangular box]

Jim Nash, Oakland County Water Resources Commissioner
Oakland-Macomb Interceptor Drain Drainage District
Odor and Corrosion Control Systems within the OMID
Construction Estimate No. 13

Construction Estimate No. 13 ✓

11/01/2025 to 11/30/2025 ✓

Department No.: 6010101
Fund No.: FND84919
Project No.: PRJ-17705
PO No.: PO00070509
Contractor: Commercial Contracting Corporation
Address: 4260 N. Atlantic Blvd
Auburn Hills, MI 48326

Account No.: 730352
Program No.: PRG149015
Activity: 1-FAC_ACQ
Vendor No.: 0000021677
Contract No.: CON0011068
Date of Contract: 7/1/2024
Completion Date: 7/1/2026

Original Contract Amount:		\$7,419,000.00
Previous Change Order Numbers (none):		\$53,276.87 ✓
Change Orders This Estimate Numbers (none):		\$0.00
Total Net Change Orders:		\$53,276.87
Adjusted Contract Amount:		\$7,472,276.87 ✓
Subtotal To Date: (Sheet 2 of 2 Column 7)		\$6,290,075.78
Less Deductions to Date: (Sheet 2 of 2 Column 7)		\$0.00
Gross Estimate: (Work in Place)	84.18%	\$6,290,075.78
Less Amount Reserved: (5% of Adjusted Contract Amount)		\$373,613.84
Total Amount Allowed To Date:		\$5,916,461.94
Less Previous Estimates:		\$4,461,171.59 ✓
Net Payment Request To Be Paid To Contractor:		\$1,455,290.35
Reserve Payment to Contractor		\$0.00
Balance to Finish	\$1,182,201.09 ✓	Accounting Auditor: HDG 12/3/25

Less Previous Transfers To Reserve: \$373,613.84 ✓

Amount of Current Transfer: \$0.00

Prepared and Recommended by: Jason D. Matteo, P.E. Date: 04-Dec-2025
Signed by: 0615e7195ff4433...
 Approved by: Jennifer Cook, P.E. Date: 05-Dec-2025
DocuSigned by: B01F3B52B9A44E9
 Approved by: Stephen Downing Date: 05-Dec-2025
Signed by: E64F4C7...
 Approved by: Joel Brown, P.E. Date: 10-Dec-2025
Signed by: 90478AE6B70E45B...

Approved by OMIDDD Drain Board on: _____

[Empty rectangular box]

OAKLAND MACOMB INTERCEPTOR DRAIN DRAINAGE BOARD
For Construction of the NI-EA OMID Contracts 2 A and 2 B - PCI 18 and 19 Rehabilitation
Located in the City of Detroit, Wayne County, Michigan

Regular Construction Estimate No. 09 (Contract NIEA OMID 2-B Only) ✓ Period: Nov. 01 through Nov. 30, 2025 ✓

Department No.:	6010101	Account No.:	SC 731472
	FND84918	Program No.:	PRG 149015
Project No.:	PRJ-17408	Activity:	1-FAC-ACQ

Contractor:	Vendor # TBD Contract # 10396	
Z Contractors, Inc.	License # 07130 exp. 4-30-25	NTP 3/10/25
50500 Design Lane	Final Completion Date: March 13,2026	(Adjusted- C.O.#0003)
Shelby Township, MI 48315		

Original Construction Contract Amount	(Contract 2-B, Only)	\$3,108,150.00
Previous Change Orders		\$961,543.93 ✓
Change Orders This Estimate: None		\$0.00
Total Net Change Orders:		\$961,543.93
Adjusted Contract Amount: (Contract 2B Only)		\$4,069,693.93 ✓
Total Earned to Date		\$1,577,130.09
Less Deductions: None		\$0.00
Gross Estimate, Work in Place	39 % Complete	\$1,577,130.09
Less Amount Reserved : 10% of amount earned		\$157,713.01
Total Amount Allowed To Date:		\$ 1,419,417.08
Less Previous Estimates		\$ 1,386,837.99 ✓
Net Pay Request To Be Paid To Contractor:		\$32,579.09
Reserve Payment to Contractor:		\$0.00
Balance to Finish: \$ 2,492,563.84 ✓	Accounting Auditor: HDG 12/2/25	
Amount to be Reserved from Above		\$157,713.01
Less Previous Transfers To Reserve:		\$154,093.11 ✓
Additional Value of Reserve for this Application		\$3,619.90

DocuSigned by: Lawrence T. Gilbert
 Prepared by: Lawrence T. Gilbert
 Lawrence T. Gilbert, P.E.; NTH Consultants Ltd. Date: 12/8/2025

Signed by: Saju Sachidanandan
 Recommended by: Saju Sachidanandan
 Saju Sachidanandan, P. E.; NTH Consultants Ltd. Date: 12/9/2025

Signed by: Jennifer Cook
 Recommended by: Jennifer Cook
 Jennifer Cook, P.E.; Oakland County WRC Date: 12/9/2025

DocuSigned by: Stephen Downing
 Recommended by: Stephen Downing
 Stephen Downing; Macomb County OPWC Date: 12/10/2025

Signed by: Joel Brown, P.E.
 Recommended by: Joel Brown, P.E.
 Joel Brown, P.E.; Oakland County WRC Date: 12/11/2025

Approved By Board On: _____

Agenda Item No. 8

Status of OMID Repairs Project

Oakland Macomb Interceptor Drain Drainage District (OMIDDD)

Progress Update for Various Rehab Projects

Prepared by:

F. Klingler, P.E., B. Kelly, P.E., FK Engineering Assoc.

L. Gilbert, P.E., NTH Consultants, Ltd.

J. Michalski, P.E., Applied Science, Inc.; T. Moore, Metco Services, Inc.

J. Matteo, P.E., Jacobs Consultants Inc.

December 17, 2025 OMIDDD Board Meeting

The following provides a status update as of the writing of this report (December 10, 2025) for the work completed for the Oakland-Macomb Interceptor Drain Repair Program (SRF Segments 1-4; Contract 7 PCI-4 repairs; Maintenance Repairs in PCI-5 through PCI-11A; Control Structure Modifications; NIEA Repairs; NESPS Upgrades; Odor/ Corrosion Control System, and other related work):

SRF Segment 1 Status:

Contracts 1&2: Complete

System-wide Odor/Corrosion Study: Complete

Odor/Corrosion Control Systems: Construction NTP Sept. 10, 2024

Amount Invoiced:

- CCC Construction Contract Value (including C.O. #1): \$7,472,276.87
- Total CCC Spent (including Pay Est. No. 12, through October 31, 2025) (10% Retainage: \$373,613.84) \$4,834,785.43
- Jacobs Team Project Budget (with EWO#5): \$2,375,161.86
- Total Jacobs Spent (Invoice No. 30, through October 24, 2025): \$1,542,659.42

Schedule Status:

- Construction Notice to Proceed was September 10, 2024.
- Substantial Completion for ST-S-1 is currently on time (March 7, 2026). Substantial Completion for ST-S-3 is now January 5th, 2026.
- Final Completion for the overall project of April 25, 2026 remains unchanged and is currently on time.

Status of Major Project Tasks:

- CCC set the activated carbon vessel on saddles in the ST-S-3 (Sorrento Boulevard/Dodge Park Road) replica house. The fan and prefilter were delivered. Masonry work of the replica house is now 100% complete. Underground electrical and mechanical work is now 100% complete. Ductwork fabrication and installation is in progress.
- CCC set the concrete equipment pad at the ST-S-1 site (Utica Road and Dodge Park Road) and is preparing to pour curb, gutter, and drive approach. Carbon vessel has been delivered and set onto the equipment pad. Ducts have been delayed to Mid-February.
- Guard posts and protective grating have been installed at the remote PCI-7 manhole and control structure sites.
- Key submittals for long-lead equipment items continue to be prepared by CCC for Jacobs to review.

- Jacobs evaluated provisions to add odor control “polishing” at the ST-S-3 site, if determined to be desired in the future. A work change directive was prepared and issued to CCC. No modifications to the replica house are necessary.
- Jacobs conducted an odor study at Control Structure No. 9 (10 Mile Road and the ITC Corridor in City of Warren) due to ongoing odor complaints. This additional effort is covered under two contract amendments (EWO #4 and EWO #5). Jacobs provided a summary of initial findings based on CS-9 data collected by MCPWO and is planning on an updated presentation to the Board in January or February 2026 based on the new data. Additional odor/corrosion monitoring, in coordination with the NI-EA sewer lining pilot, is currently on hold.
- Coordination with MCPWO Drop Shaft Rehabilitation project is ongoing.



Construction of brick face of north wall at ST-S-3 site (looking south)



Construction of brick face of south wall at ST-S-3 site (looking north)



ST-S-1 site construction status (Dodge Park Road and Utica Road, looking east)

SRF Segment 2 (Contract 3) Status: Complete

SRF Segment 3 (Contract 4) Status: Complete

SRF Segment 4 (Contracts 5-7) Status: Complete

NESPS Odor/Corrosion Control System: Complete

NESPS & OMID Maintenance, Operations & Upgrades Status:

Status of Emergency Contingency Plan for pumping during total power loss or other catastrophic system failure:

- Mersino is under contract for standby emergency bypass pumping. No activity this month.
- The OMIDDD Project Team has finalized design (pending final property agreements) for keeping the 15 Mile Road bypass pumping arrangement (initially constructed in summer 2021) intact and buried. Solicitation of bids is on hold pending negotiations and final agreement with ITC and other property owners. Continuing pursuit of a perpetual licensing agreement with ITC, with some progress this month.
- Remaining items in the final emergency plan include punch-list and modifications at the 15 Mile Road Site, and overall optimization of the Emergency Plan per above. The final plan document will be revised after final installation (bury) of the emergency pumping conveyance conduit.

Additional work being performed under Metco Maintenance Contract for NESPS:

- Mechanical and Electrical corrective/preventative maintenance schedules continue.
- Coordination between OMIDDD, GLWA, MIDD, and Pump/Electrical Upgrade Project is ongoing and has not impacted station operations or the ability to meet demand.
- Punch list items continue to be addressed (elevator permits and related generator and electrical items).

- Wet Well elevator (installed as part of NESPS Upgrades project) was inspected by the City of Detroit; final inspection pending. Lardner is addressing issues noted by the City Inspector related to the generator. The City also requested a partial enclosure of the lower elevator shaft to prevent entry of debris; this work is complete.
- Both north and south bar screens were cleaned in the last reporting period. Next inspection/cleaning is scheduled for December 16, as a differential has been observed recently on the south bar screen.
- Sanitary Pump #4 variable frequency drive and pump continue to perform well. So far, no unusual conditions to report.
- The new pump auto sequencing workshops are now complete (last period) and a wet weather sequencing test is now planned for early January.



Relocation of stored items to new laydown area



Renewed inspection on diesel tanks #1 and #2, valid for 3 years

Overall NESPS Station Performance and Maintenance Report by METCO:

- Mechanical: Sanitary Pumps #1, 3, 4, 6, and dewatering pump are ready for duty at the time of this report. Pumps 3 & 4 have been plugged to accommodate downstream work; plugs now removed during a pause in this work. Current Total Pumping Capacity equals 330cfs. Contract Capacity is 423cfs with a Firm Capacity of 400cfs.
- Sanitary Pump 5 is currently out of service with a lube-oil issue (leak and poor oil circulation); Walsh is coordinating service to diagnose and repair pump.
- Investigation into Sanitary Pump 2 has indicated that there are electrical issues with the VFD and likely the excitor. Inomatics, Motor City Electric and Ideal Motor have investigated the issue; further evaluations and testing are needed to further diagnose issue and make a final conclusion on the best approach for repair/rebuild (or possible replacement).
- The inflatable plugs (that were in use to accommodate flow control on Contract 2B) have been removed from Pump #3 and Pump #4 and are on standby.
- NESPS/GLWA LOTO (Lock-Out Tag-Out) protocols continue as a primary means of safety communication.
- New dry well submersible Sump Pumps #1 and #2 continue to perform with no issues.
- CMMS: NEXGEN asset management in use. Monthly status meetings are being held with OMIDDD. Contractors are fulfilling their NEXGEN requirements with no outstanding issues.
- HVAC: New oxygen sensors are performing as designed. Rounds are conducted daily. Station ventilation and gas detection continue to be closely monitored. Unit air filters are re-stocked and changed as required. New fire alarm system tested and inspected are ready for duty. System training completed.
- Bio Filter performance has been acceptable. No odor-related complaints have been reported.
- Overall General Housekeeping tasks remain in order. Minor maintenance activities continue to be addressed in a timely manner.

Control Structures Performance Report (CS-5, CS-6, CS-7, CS-8, CS-9):

- Daily flow control operations using the control structures continue to support MID/OMID/NIEA repair and improvement projects. (Weather permitting).
- No odors noticed by OMIDDD personnel during normal field operations. Routine manhole cover inspections within the ITC Corridor will re-commence next summer.
- All LOTO protocols remain in place.
- System-wide communications are good.
- CS-9, CS-6, CS-7 and CS-8 gates are in stand-by mode and ready for service, although CS-8 is not fully operational due to a thrust nut issue.
- CS-9 hydraulic oil leaks apparently at the limit switch connector); Hesco to inspect and further diagnose issue.
- CS-5 had a leaky cylinder in CS-5 Gate #1, fully repaired on December 8 and now fully functional.

- Routine daily rounds and inspections are ongoing.



CS-5 Cylinder Repair



CS-5 Cylinder Repair

Other System Operation Issues

- O&M Manual is currently being revised to include new structures, recently modified structures, new monitoring equipment, EGLE approval of gate use for long term flow management, and recent inspection and repair status.

OMID Control Structure Upgrades Status (on hold):

- ASI is complete with design of major upgrades to control structures which takes into consideration long-term operability.
- Currently considering options for contract delivery (i.e., one or multiple contracts, etc.)
- Currently evaluating potential impacts on other projects and best timing for construction, tentatively planned for early 2026, starting with CS-7 and CS-8.

OMID System 6-Year Inspection and Related Repair Status:

All inspections are complete and the final report has been finalized. PCI-10 and PCI-11 repairs identified during the inspection are planned for repair and coordination is underway with a task-order contractor to establish a schedule for PCI-10 and PCI-11 defects.

NIEA Rehabilitation

Contract 1 (PCI-4 Rehabilitation): Complete

Contract 2A and 2B (PCI-18/19 Rehab): In Construction

Amt Invoiced: Contract 2A has completed \$8,101,975.24 out of \$8,101,975.24 (100% Contract Value complete). Contract 2B has completed \$1,540,931.10 out of adjusted contract value of \$4,069,693.93 (36% Contract Value complete).

Schedule Status: Contract 2A: Final completion was achieved. Flow diversion testing continues. Contract 2B: NTP was March 10, 2025; currently projecting completion in mid-March 2026. With further extensions likely.

Contract 2A/2B (PCI -18/19 Rehabilitation) Construction Status:

- Construction of the Seven Mile diversion shaft and PC 663 main bulkhead gate (including hardware and instrumentation) is complete under Contract 2A.
- Contract 2B has been largely idle during this reporting period while flow diversion issues are resolved. Debris removal and chemical grouting is complete in PCI-19 and planning for lining is ongoing. After about 3 weeks of flow diversion to the 7 Mile Relief sewer prior to lining, odor issues forced the diversion to be temporarily halted. A temporary chemical storage and injection facility has been placed at NESPS to mitigate downstream odors with a regulated dosage of ferric chloride available as needed during flow diversion. Odor monitoring equipment with dataloggers have also been installed at 5 locations, providing up-to-date reporting of H₂S odor concentrations and adjusted chemical dosage rates. Eganix (more formally identified as Syneco Products "Peacemaker" products) manhole inserts have apparently been successful at controlling odors local to manholes.

- Coordination efforts between Contract 2B and downstream DRI work by GLWA continue. Coordination meetings occur monthly, with future meetings scheduled as necessary.
- A pilot study monitoring protocol is developed. Baseline inspections will begin later in 2025.
- NESPS Issues related to the NI-EA Contract 2B rehab work:
 - PC-663 Flow Diversion resumed in November 2025 with occasional interruptions due to system requirements and downstream odor issues.
 - Downstream odor issues possibly related to the NIEA C2B work appeared to be partially reduced, following installation of localized H₂S neutralizers (Syneco Peacemaker manhole inserts, Ferric Chloride injection) and experimentation with flow control sequencing. PC-663 Flow Diversion is now temporarily halted pending consideration of modifications to the flow control approach, to minimize downstream odors.



PCI-19-MH-102 during project idle

The **draft** line item schedule and budgets for OMID NIEA Contracts 1 and 2 are summarized:

Work Item/ Milestone	Estimated Budget Expenditure (Engineering)	Estimated Budget Expenditure (Contractor)	Estimated Delivery Date
Contract Award and NTP			12/16/2020 and 1/04/2021 (Contract 1) 6/20/23 and 7/1/23 (Contract 2)
Subtotal - Design	\$2,400,570		
Completion of Construction	\$3,500,000	\$28,630,000	Contract 1, SC at 1/24; FC 4/24 Contract 2A& B, est. SC at 3/26 and FC 4/26.

NESPS Pump and Electrical Upgrades Project

Budget Status: The total construction amount invoiced as of June 30, 2025 is \$ 49,125,101.02 out of \$ 51,398,400.35 budget (adjusted contract value, including the operational Control Structure 9 Bulkhead Gate facility and adjusted for stored material inclusion in major work activities), representing 96% of the Pump & Electrical Upgrades Project, with additional change order additions equalizing the regular work completion values.

Schedule Status: Work delay is 24 months beyond current approved contract completion date.

The following Design Team and Construction Services Effort is active:

- Construction Phase services are ongoing, primarily to address punch list and final completion details. The engineering team continues reviewing and responding to issues as they arise.
- The new Sewage Pumps #1, #3, #5, and #6 have been installed with all 4 pumps approved for provisional use although they are currently operating below design capacity. “Flow-fin” vanes were installed in the Pump #6 influent piping/spool to address “pre-swirl” effects. This retrofit appears to have had some positive effect, although the overall impact is modest.
- Sanitary Pump #2 is out of service awaiting the installation of replacement parts and further evaluation of the most cost-effective approach for VFD rehabilitation or replacement (see above).
- Sanitary Pump #3 was out of service due to isolation plug failure, now back in service. Pump #3 and #4 have been returned to regular available service, restoring the Station to full pumping capacity (minus Pump #2 and Pump #5; see above).
- Station wide interior improvements continue. Touch up painting and the cleaning of floors 2 through 5 is ongoing.
- Installation of the new wet well elevator is complete with an inspection pending (see above).
- A review of alternative energy saving methods and pump sequence remains ongoing, incorporating GLWA SCC comments.
- Punch list items include fire alarm systems, Wet Well elevator work and related elevator permitting in the existing NESPS building is approaching final completion.
- The new duplex sump pumps, including floats and level controls, are operational in the dry well pipe gallery sump area.
- Discussions continue regarding global settlement of various issues during construction. (August 23, 2022 Arc-Flash incident, pump performance, schedule issues, and others).

The **draft** line item schedule and budget are summarized:

Work Item/ Milestone	Design/CCA Budget	Const Budget	Estimated Delivery Date
2 Final Basis of Design			5/31/2019
9 Final Package Development			8/14/2020
Subtotal	\$3,826,000		
10 Substantial Completion	\$2,500,000 (est.)	\$49,125,101	Sept 30 2025 (late)
11 Final Completion		\$51,398,400	Dec 2025 (late)

OMID Improvements at CS-6 Site (lining btwn CS-12 & CS-4)



Fence installation underway

Site restoration is largely complete with the installation of the permanent fence ongoing. Transition between tunnel and shaft opening at CS-12 is the only remaining OMIDDD item; to be completed when flow control allows in the spring.

Summary of OMID Design and Construction Status:

Work In Construction Since 2009							
Seg. No	Contract No. (Description)	Contractor	Const. Comp?	As-Builts Final?	Balancing Change Order?	Contractor Closed Out?	Easements Settled?
1	Contract 1 (CS-9, 5, 3)	Ric-Man	Y	Y	Y	Y	Y
1	Contract 2 (CS-6, 7, 8)	Ric-Man	Y	Y	Y	Y	Y
2	Contract 3-2E (Gatehouse)	IWPC (Weiss)	Y	Y	Y	Y	N/A
2	Contract 3 (Grouting PCI-5 thru 8)	IWPC	Y	Y	Y	Y	Y
3	Contract 4 (Lining PCI-5 thru 8)	Jay Dee Cont.	Y	Y	Y	Y	Y
4	Contract 5 (Lining PCI-9, 10A/B)	Lanzo	Y	Y	Y	Y	N
4	Contract 6 (Lining PCI-11A)	Lanzo	Y	Y	Y	Y	Y
N/A	Contract 7 (Lining 110' of NIEA)	IWPC	Y	Y	Y	Y	N/A
N/A	Odor/Corrosion Control System	CSM	Y	Y	Y	Y	N/A
N/A	Control Structure Modifications	CSM/Hesco/MCE	Y/Y/Y	Y/Y/Y	Y/Y/Y	Y/Y/Y	N/A
N/A	OMID Maintenance Repairs	Doetsch	Y	Y	Y	Y	N/A
N/A	CS-9 Gate Modifications	Walsh as CMR	Y	Y	Y	Y	Y
N/A	NESPS Pump & Electrical Upgrade	ASI;Walsh as CMAR	N	N	N	N	Y
N/A	3-year inspection and repairs	Doetsch	Y	Y	Y	Y	N/A
N/A	6-year inspection	Doetsch	Y	Y	Y	Y	N/A
N/A	NIEA-OMIDDD Contract 1 (PCI-4)	Marra	Y	Y	Y	Y	Y
N/A	NIEA-OMIDDD Cont 2 (PCI-18/19)	Z Contractors	N	N	N	N	N
Work Currently in Design/Study/Engineering							
Description		Design Consultant	Status				
System-wide Odor/Corrosion Design		Jacobs	Design and bidding Complete, award to CCC pending				
NESPS & OMID Maintenance & Repairs		Metco	Engineering/Maintenance Ongoing				
Emergency Pumping Plan		ASI/NTH/FKE	Draft Plan to be modified following ITC bypass pumping modifications				
Control Structure Upgrades		ASI	Design Complete; On hold for bidding				

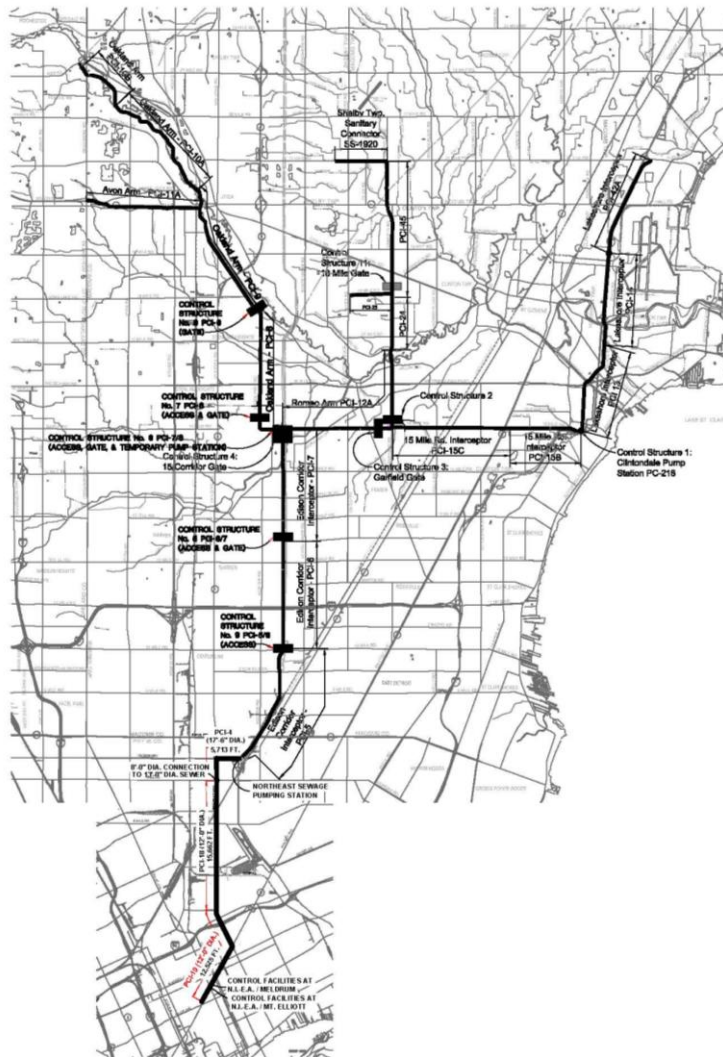

Overview of OMID System in Oakland, Macomb, and Wayne County

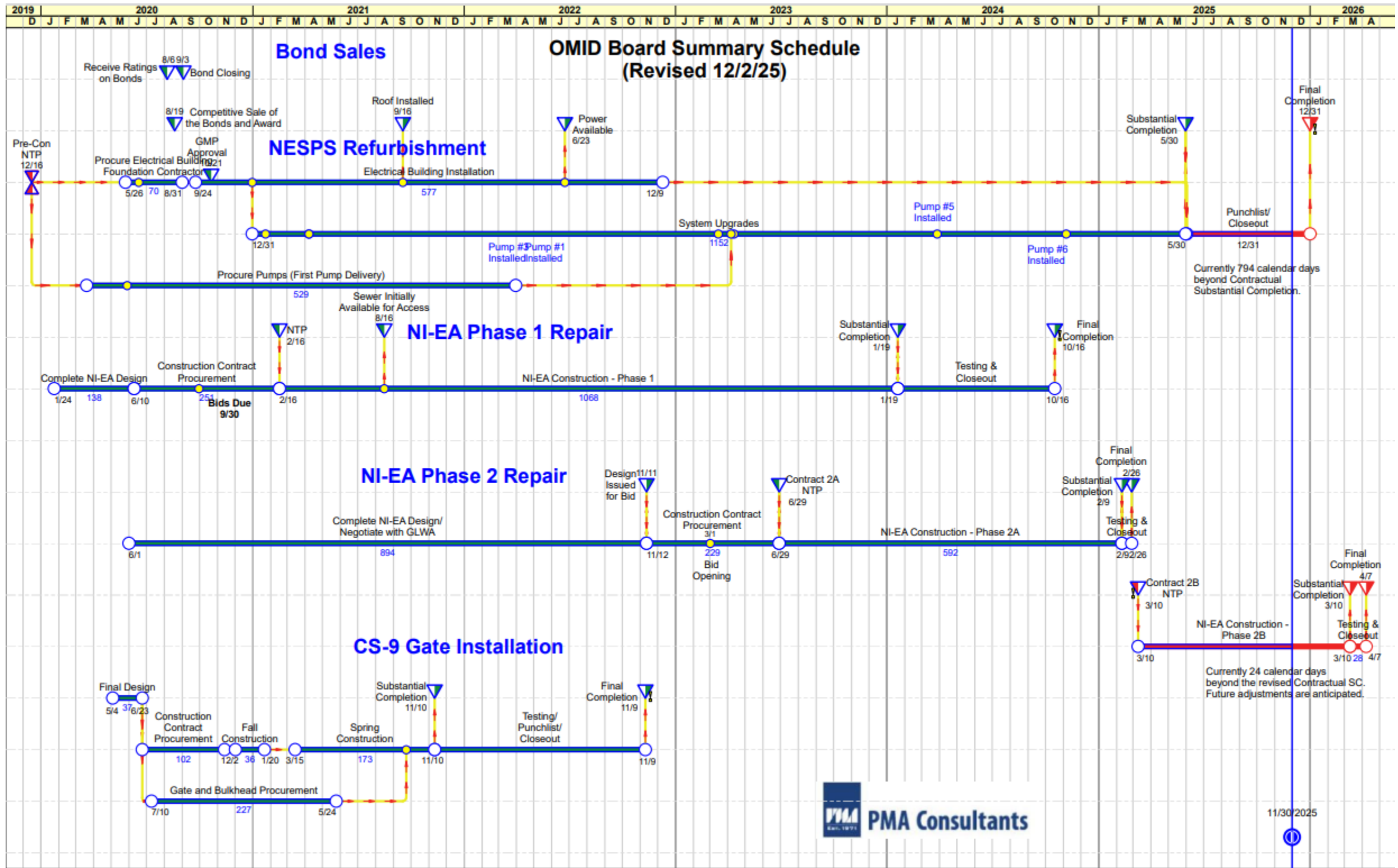

OMID Project Schedule Summary

Agenda Item No. 9

Financial Reports – General Financial Report and
Status of State Revolving Fund Financing and
Other Financing

YTD Trial Balance Fund: 84917 Oakland Maccomb InterceptorSeg5 As of Fiscal Period: Month 2, 2026		OMID SEGMENT 5 BOND ISSUE PRJ-13252	OMID NI-EA CONSTRUCTION PRJ-13308	NESPS MECH-ELEC CONSTRUCTION PRJ-13309	YTD Balance
100100	Cash - Operating	3,387,801.95	3,893,618.80	(257,991.42)	7,023,429.33
143100	Prepaid Expenses			66,123.98	66,123.98
	ASSETS	3,387,801.95	3,893,618.80	(191,867.44)	7,089,553.31
211100	Due to Primary Government	0.00	(16,243.53)	(42,311.69)	(58,555.22)
	LIABILITIES	0.00	(16,243.53)	(42,311.69)	(58,555.22)
655000	Income From Investments	0.00		(21,454.96)	(21,454.96)
	REVENUES	0.00	0.00	(21,454.96)	(21,454.96)
730000	Contractual Services		0.00	(116,760.33)	(116,760.33)
770000	Internal Support Expenditures		889.36	15,604.16	16,493.52
	EXPENSES	0.00	889.36	(101,156.17)	(100,266.81)
381315	FB Restricted Debt	(47,288,433.00)			(47,288,433.00)
382100	FB Committed for Capital Proj	43,900,631.05	(3,878,264.63)	356,790.26	40,379,156.68
	Fund Balance	(3,387,801.95)	(3,878,264.63)	356,790.26	(6,909,276.32)
		(0.00)	0.00	0.00	(0.00)

Cash as of 11/30/2025 \$ 7,023,429.33

Invoices/Reimbursements for NESPS Mech / Electrical Construction on Current Agenda impacting Cash Balance (2,252,150.78)

Total Net Cash Balance \$ 4,771,278.55

OCM Project Work In Progress

Company Oakland County
Projects and Project Hierarchies PRJ-13308 OMID NI-EA CONSTRUCTION
Budget Structure Project Task
Budget Name
Period FY2026 - Nov
Project Status for Actuals
Project Status for Budget

Project	Final Budget	Actuals MTD	Commitments YTD	Obligations YTD	Actuals YTD	Total Spend YTD	Actuals LTD	Variance
Project Expenses	28,395,600.00	308.44	-	-	889.36	889.36	24,329,480.79	4,066,119.21
1 > Administration	584,000.00	308.44	-	-	889.36	889.36	196,713.00	387,287.00
1 > Contingency	2,581,000.00	-	-	-	-	-	-	2,581,000.00
1 > Engineering	478,000.00	-	-	-	-	-	317,320.59	160,679.41
1 > Engineering Consultants	4,913,000.00	-	-	-	-	-	5,877,676.59	(964,676.59)
1 > Facility Acquisition	17,983,600.00	-	-	-	-	-	17,400,876.92	582,723.08
1 > Inspection	260,000.00	-	-	-	-	-	-	260,000.00
1 > Legal and Financial	1,259,000.00	-	-	-	-	-	251,349.59	1,007,650.41
1 > Right of Way	265,000.00	-	-	-	-	-	86,378.76	178,621.24
1 > STANDARD	40,000.00	-	-	-	-	-	199,165.34	(159,165.34)
1 > Survey	32,000.00	-	-	-	-	-	-	32,000.00
Project Revenues	-	-	-	-	-	-	28,206,856.06	
RC605572 - Special Assessments Revenue	-	-	-	-	-	-	6,235,012.99	
RC697551 - Issuance of Bonds	-	-	-	-	-	-	21,965,099.65	
RC698200 - Insurance Recoveries	-	-	-	-	-	-	6,743.42	
Revenue Over/ (Under) Expenses							3,877,375.27	

OCM Project Work In Progress

Company Oakland County
Projects and Project Hierarchies PRJ-13309 NESPS MECH-ELEC CONSTRUCTION
Budget Structure Project Task
Budget Name
Period FY2026 - Nov
Project Status for Actuals
Project Status for Budget

Project	Final Budget	Actuals MTD	Commitments YTD	Obligations YTD	Actuals YTD	Total Spend YTD	Actuals LTD	Variance
Project Expenses	54,086,000.00	54,522.70	-	-	(101,156.17)	(101,156.17)	54,730,182.80	(644,182.80)
1 > Administration	620,000.00	1,079.54	-	-	2,111.16	2,111.16	98,648.18	521,351.82
1 > Contingency	4,917,000.00	-	-	-	-	-	-	4,917,000.00
1 > Engineering	446,000.00	5,210.05	-	-	6,135.72	6,135.72	406,524.83	39,475.17
1 > Engineering Consultants	3,987,000.00	12,269.95	-	-	(112,730.05)	(112,730.05)	5,324,974.93	(1,337,974.93)
1 > Facility Acquisition	40,857,000.00	-	-	-	-	-	45,927,100.10	(5,070,100.10)
1 > Inspection	285,000.00	3,141.12	-	-	7,357.28	7,357.28	492,917.95	(207,917.95)
1 > Legal and Financial	2,417,000.00	32,822.04	-	-	(4,030.28)	(4,030.28)	1,231,922.92	1,185,077.08
1 > Right of Way	393,000.00	-	-	-	-	-	-	393,000.00
1 > STANDARD	130,000.00	-	-	-	-	-	1,245,943.58	(1,115,943.58)
1 > Survey	34,000.00	-	-	-	-	-	2,150.31	31,849.69
Project Revenues	-	21,454.96	-	-	21,454.96	(21,454.96)	54,496,003.67	
RC605572 - Special Assessments Revenue	-	-	-	-	-	-	11,867,450.70	
RC655385 - Income from Investments	-	21,454.96	-	-	21,454.96	(21,454.96)	21,454.96	
RC697551 - Issuance of Bonds	-	-	-	-	-	-	41,837,622.01	
RC698200 - Insurance Recoveries	-	-	-	-	-	-	769,476.00	
Revenue Over/ (Under) Expenses							(234,179.13)	

OCM Project Work In Progress

Company Oakland County
Projects and Project Hierarchies PRJ-13252 OMID Segment 5
Budget Structure Project Task
Budget Name
Period FY2026 - Nov
Project Status for Actuals
Project Status for Budget

Project	Actuals MTD	Commitments YTD	Obligations YTD	Actuals YTD	Total Spend YTD	Actuals LTD	Variance
Project Expenses	-	-	-	-	-	757,136.57	(757,136.57)
1 > Administration	-	-	-	-	-	242,201.57	(242,201.57)
1 > Legal and Financial	-	-	-	-	-	514,935.00	(514,935.00)
Project Revenues	-	-	-	-	-	4,144,938.52	
RC605572 - Special Assessments Revenue	-	-	-	-	-	894,060.05	
RC655077 - Accrued Interest Adjustments	-	-	-	-	-	86,724.04	
RC655385 - Income from Investments	-	-	-	-	-	2,078,067.10	
RC655462 - Increase Market Value Investment	-	-	-	-	-	1,084.24	
RC697219 - Premiums on Bonds Sold	-	-	-	-	-	7,672,724.75	
RC697551 - Issuance of Bonds	-	-	-	-	-	(6,587,721.66)	
Revenue Over/ (Under) Expenses						3,387,801.95	

YTD Trial Balance Fund: 84918 NIEA Contract #2 As of Fiscal Period: Month 2, 2026		NIEA Contract #2 Construction PRJ-17408	YTD Balance
100100	Cash - Operating	8,131,244.87	8,131,244.87
	ASSETS	8,131,244.87	8,131,244.87
201210	Vouchers Payable AP Cont	(240,983.81)	(240,983.81)
211100	Due to Primary Government	(10,055.17)	(10,055.17)
222300	Unearned Revenues	(2,467,625.37)	(2,467,625.37)
	LIABILITIES	(2,718,664.35)	(2,718,664.35)
655000	Income From Investments	(25,177.18)	(25,177.18)
	REVENUES	(25,177.18)	(25,177.18)
730000	Contractual Services	139,537.25	139,537.25
770000	Internal Support Expenditures	12,979.95	12,979.95
	EXPENSES	152,517.20	152,517.20
382100	FB Committed for Capital Proj	(5,539,920.54)	(5,539,920.54)
	Fund Balance	(5,539,920.54)	(5,539,920.54)
		0.00	0.00

Cash as of 11/30/2025 \$ 8,131,244.87

Invoices/Reimbursements for Construction PRJ-17408 on Current Agenda impacting Cash Balance (105,483.00)

Total Net Cash Balance \$ 8,025,761.87

OCM Project Work In Progress

Company Oakland County
Projects and Project Hierarchies PRJ-17408 NI-EA C2 PCI 18&19 Rehab
Budget Structure Project Task
Budget Name
Period FY2026 - Nov
Project Status for Actuals
Project Status for Budget

Project	Final Budget	Actuals MTD	Commitments YTD	Obligations YTD	Actuals YTD	Total Spend YTD	Actuals LTD	Variance
Project Expenses	15,600,000.00	346,512.55	-	-	152,517.20	152,517.20	11,624,308.69	3,975,691.31
1 > Administration	95,287.00	308.44	-	-	1,161.88	1,161.88	137,011.89	(41,724.89)
1 > Engineering	235,465.00	7,875.37	-	-	11,818.07	11,818.07	37,939.25	197,525.75
1 > Engineering Consultants	2,089,000.00	70,568.96	-	-	69,103.13	69,103.13	1,805,817.47	283,182.53
1 > Facility Acquisition	12,596,000.00	267,759.78	-	-	71,434.12	71,434.12	9,188,844.94	3,407,155.06
1 > Inspection	230,037.00	-	-	-	-	-	-	230,037.00
1 > Legal and Financial	279,000.00	-	-	-	(1,000.00)	(1,000.00)	-	279,000.00
1 > Right of Way	42,000.00	-	-	-	-	-	-	42,000.00
1 > STANDARD	15,796.00	-	-	-	-	-	454,695.14	(438,899.14)
1 > Survey	17,415.00	-	-	-	-	-	-	17,415.00
Project Revenues	-	25,177.18	-	-	25,177.18	(25,177.18)	17,036,889.21	
RC605572 - Special Assessments Revenue	-	-	-	-	-	-	7,094,817.63	
RC631827 - Reimb General	-	-	-	-	-	-	3,375,000.00	
RC655385 - Income from Investments	-	25,177.18	-	-	25,177.18	(25,177.18)	660,193.13	
RC697219 - Premiums on Bonds Sold	-	-	-	-	-	-	176,878.45	
RC697551 - Issuance of Bonds	-	-	-	-	-	-	5,730,000.00	
Revenue Over/ (Under) Expenses							5,412,580.52	

YTD Trial Balance FND84919 OMIDDD Odor and Corrosion Control As of Fiscal Period: Month 2, 2026		OMID Odor/Corrosion System Construct PRJ-17705	YTD Balance
100100	Cash - Operating	4,904,588.11	4,904,588.11
	ASSETS	4,904,588.11	4,904,588.11
211100	Due to Primary Government	(74,089.32)	(74,089.32)
222300	Unearned Revenues	(3,568,289.03)	(3,568,289.03)
275600	NC Unamortized Premium on Bond	(187,885.50)	(187,885.50)
	LIABILITIES	(3,830,263.85)	(3,830,263.85)
655000	Income From Investments	(20,942.77)	(20,942.77)
	REVENUES	(20,942.77)	(20,942.77)
730000	Contractual Services	600,985.43	600,985.43
770000	Internal Support Expenditures	36,216.22	36,216.22
	EXPENSES	637,201.65	637,201.65
382100	FB Committed for Capital Proj	(1,690,583.14)	(1,690,583.14)
	Fund Balance	(1,690,583.14)	(1,690,583.14)
		0.00	0.00

Cash as of 11/30/2025 \$ 4,904,588.11

Invoices/Reimbursements for Construction PRJ-17705 on Current Agenda impacting Cash Balance (1,508,768.83)

Total Net Cash Balance \$ 3,395,819.28

OCM Project Work In Progress

Company Oakland County
Projects and Project Hierarchies PRJ-17705 OMID Odor/Corrosion System Construct
Budget Structure Project Task
Budget Name
Period FY2026 - Nov
Project Status for Actuals
Project Status for Budget

Project	Final Budget	Actuals MTD	Commitments YTD	Obligations YTD	Actuals YTD	Total Spend YTD	Actuals LTD	Variance
Project Expenses	11,400,000.00	626,925.42	-	3,011,105.29	637,201.65	3,648,306.94	6,814,547.01	4,585,452.99
1 > Administration	-	462.66	-	-	735.14	735.14	133,163.95	(133,163.95)
1 > Contingency	747,000.00	-	-	-	-	-	-	747,000.00
1 > Engineering	193,000.00	4,552.68	-	-	6,870.56	6,870.56	98,416.95	94,583.05
1 > Engineering Consultants	2,350,000.00	66,752.79	-	-	56,752.79	56,752.79	1,542,660.45	807,339.55
1 > Facility Acquisition	7,419,000.00	544,232.64	-	3,011,105.29	544,232.64	3,555,337.93	4,834,785.43	2,584,214.57
1 > Inspection	295,000.00	10,924.65	-	-	28,610.52	28,610.52	116,979.34	178,020.66
1 > Legal and Financial	310,000.00	-	-	-	-	-	55,076.15	254,923.85
1 > Right of Way	77,000.00	-	-	-	-	-	30,706.09	46,293.91
1 > STANDARD	4,000.00	-	-	-	-	-	2,758.65	1,241.35
1 > Survey	5,000.00	-	-	-	-	-	-	5,000.00
Project Revenues	-	20,942.77	-	-	20,942.77	(20,942.77)	7,888,871.27	
RC605572 - Special Assessments Revenue	-	-	-	-	-	-	4,338,716.97	
RC655385 - Income from Investments	-	(20,942.77)	-	-	(20,942.77)	(20,942.77)	395,154.30	
RC697551 - Issuance of Bonds	-	-	-	-	-	-	3,155,000.00	
Revenue Over/ (Under) Expenses							1,074,324.26	

Oakland County - Water Resources Commissioner's Office
Fund Equity: Schedule of Reserves and Dedicated Funds
As of Date: November 30, 2025

Fund	Description	Major Maintenance	Emergency Maintenance Reserve	Capital Improvement	Undesignated	Committed for Capital Projects	Total Equity
82912	OMIDD Maintenance Fund	6,040,665.86	2,724,324.84	9,362,303.01	18,393,354.73		36,520,648.44
84917	OMIDD Seg 5						
	- Project 1-3252 Interceptor Seg 5					3,387,801.95	
	- Project 1-3308 NI - EA Construction					3,877,375.27	
	- Project 1-3309 NESPS Construction					<u>(234,179.13)</u>	<u>7,030,998.09</u>
84918	OMIDDD North Interceptor East Arm – Contract #2						
	- Project: PRJ-17408 OMIDDD NIEA Contract2 Construction					<u>5,412,580.52</u>	<u>5,412,580.52</u>
84919	OMID Odor and Corrosion Control						
	- Project: PRJ-17705 OMID Odor/Corrosion System Construction					<u>1,074,324.26</u>	<u>1,074,324.26</u>
Total Equity in Maintenance and Construction Funds							<u><u>50,038,551.31</u></u>

NOTE: This report presents pre-closing figures and as such are subject to change

OAKLAND MACOMB INTERCEPTOR DRAINAGE BOARD - APPROVAL OF INVOICES/REIMBURSEMENTS

OMIDD Meeting Date 12/17/2025

		84917	84917	84918	84919	82912	
		1-3308	1-3309	1-7408	1-7705		
Payable To	Invoice #	Segment 5 NIEA Construction	Segment 5 NESPS Mech / Electric Construction	NIEA Contract #2 Construction	Odor/ Corrosion System Construct	Operations & Maintenance	Total
Oakland County *	WRC Labor/Fringes/Non-direct Labor (11/01/25 - 11/28/25)	296.48	9,164.26	8,021.88	14,777.85		32,260.47
Oakland County *	WRC Equipment (11/01/25 - 11/28/25)	11.96	266.45	161.93	1,162.14		1,602.48
Applied Science, Inc.	Invoice # 78 (ASI Inv. #9453) Services 8/31/25-11/1/25		76,800.93				76,800.93
Clark Hill PLC	Invoice #1648638 Matter 463149 Walsh Construction Svs Through 9/30/2025		2,135.00				2,135.00
Clark Hill PLC	Invoice #1657174 Matter 463149 Walsh Construction Svs Through 10/31/2025		3,710.00				3,710.00
CSM Mechanical, LLC	Invoice # 6092- Job 4240 Professional Service					470.00	470.00
HESCO (Hamlett)	Invoice # 2019807-003 WO# 1611					571.94	571.94
Jacobs Consultants, Inc.	Invoice # C6A19900-31 OMIDD Odor & Corrosion Facilities 10/25/25 - 11/21/25				53,478.48		53,478.48
Kennedy Industries	Invoice # 647319 - NEPS Pump Field Service 7/9/25					4,781.38	4,781.38
Lardner Elevator Company	Invoice # 205990 - Install roller guides and testing 6/26/25 - 6/30/25					14,998.00	14,998.00
Lardner Elevator Company	Invoice # 206473 - Elevator Maintenance September 2025					214.00	214.00
Lardner Elevator Company	Invoice # 206799 - Elevator Maintenance October 2025					214.00	214.00
METCO Consulting Engineers	Invoice # 1811-83 11/03/2025 Through 11/30/2025					92,567.51	92,567.51
Motor City Electric Technologies	Invoice # 96914 Electrical and Engineering Support 11/13/25					317.50	317.50
NTH Consultants	Invoice # 640770 (D-458 & D-463) Engineering Services 10/25/25 - 11/21/25			69,284.01			69,284.01
NTH Consultants	Invoice # 640766 Consulting Services-2021 OMID Rehabilitation 9/20/25 - 11/21/25					805.15	805.15
PM Technologies	Invoice # 130380529 Monthly Inspection Gen 3					350.00	350.00
PM Technologies	Invoice # 130380504 Monthly Inspection Gen 1					350.00	350.00
PM Technologies	Invoice # 130373457 Monthly Inspection Gen 2					350.00	350.00
PMA Consultants	Invoice # 03559.01-63 Professional Services 8/1 - 8/31/25		14,853.10				14,853.10
PMA Consultants	Invoice # 03559.01-65 Professional Services 10/1 - 10/31/25		17,436.25				17,436.25
Rotor Electric	Invoice # 12946 P2 VFD Shelter House Power Loss 10/6/25					4,503.00	4,503.00
Rotor Electric	Invoice # 12947 CS6 Power Issues 10/10/25					2,013.00	2,013.00
Rotor Electric	Invoice # 12948 P4 VFD Fan Motor Fault 10/14/25					2,013.00	2,013.00
Rotor Electric	Invoice # 12949 P3 Power Restoration 10/23/25					1,006.50	1,006.50
Rotor Electric	Invoice # 12950 P1 Trip On Start-up 11/3/25 11/03/25					1,342.00	1,342.00
Walsh Construction II, LLC	Invoice # 220008-970500 Arc Flash Insurance Payment Contractor General Conditions		2,137,215.50				2,137,215.50
Commercial Contracting Corp	Construction Estimate # 13 Odor and Corrosion Systems				1,455,290.35		1,455,290.35
Z Contractors	Construction Estimate # 9 NI-EA contract # 2B			36,198.99			36,198.99
	Total Invoices/Reimbursements for Approval	308.44	2,261,581.49	113,666.81	1,524,708.82	126,866.98	4,027,132.54
	* Less WRC Charges already paid from OMI Fund	(308.44)	(9,430.71)	(8,183.81)	(15,939.99)		(33,862.95)
	Total Invoices/Reimbursements that will impact Cash Balance listed on Current Trial Balance submitted to OMI Drain Board	0.00	2,252,150.78	105,483.00	1,508,768.83	126,866.98	3,993,269.59

Agenda Item No. 10

Invoices

OMI Segment 5 NESP Mech - Elect Construction Project - WRC Labor/Fringes/Non-Direct Labor Factor for Trans Dates -								11/1/2025	-	11/28/2025
WOID	Date Entered	Date Worked	Name/Description	Hours/Units	Cost	Cost Category	Assign Equipment	Project	Activity	
1287147	11/24/2025	10/6/2025	BROWN, JOEL	1.00	\$171.60	REGULAR	WRCCON	PRJ-13309-1-ENGINEERING		
1287147	11/24/2025	10/8/2025	BROWN, JOEL	1.00	\$171.60	REGULAR	WRCCON	PRJ-13309-1-ENGINEERING		
1287147	11/24/2025	10/9/2025	BROWN, JOEL	1.00	\$171.60	REGULAR	WRCCON	PRJ-13309-1-ENGINEERING		
1287147	11/24/2025	10/10/2025	BROWN, JOEL	2.50	\$429.00	REGULAR	WRCCON	PRJ-13309-1-ENGINEERING		
1287147	11/24/2025	10/13/2025	BROWN, JOEL	1.00	\$171.60	REGULAR	WRCCON	PRJ-13309-1-ENGINEERING		
1287147	11/24/2025	10/14/2025	BROWN, JOEL	4.00	\$686.40	REGULAR	WRCCON	PRJ-13309-1-ENGINEERING		
1287147	11/24/2025	10/15/2025	BROWN, JOEL	3.00	\$514.80	REGULAR	WRCCON	PRJ-13309-1-ENGINEERING		
1287147	11/24/2025	10/20/2025	BROWN, JOEL	3.00	\$514.80	REGULAR	WRCCON	PRJ-13309-1-ENGINEERING		
1287147	11/24/2025	10/24/2025	BROWN, JOEL	0.50	\$85.80	REGULAR	WRCCON	PRJ-13309-1-ENGINEERING		
1287147	11/24/2025	10/27/2025	BROWN, JOEL	1.00	\$171.60	REGULAR	WRCCON	PRJ-13309-1-ENGINEERING		
1287147	11/24/2025	10/28/2025	BROWN, JOEL	1.00	\$171.60	REGULAR	WRCCON	PRJ-13309-1-ENGINEERING		
1287147	11/24/2025	10/29/2025	BROWN, JOEL	1.00	\$171.60	REGULAR	WRCCON	PRJ-13309-1-ENGINEERING		
1287147	11/24/2025	10/30/2025	BROWN, JOEL	2.00	\$343.20	REGULAR	WRCCON	PRJ-13309-1-ENGINEERING		
1287147	11/24/2025	10/31/2025	BROWN, JOEL	4.00	\$686.40	REGULAR	WRCCON	PRJ-13309-1-ENGINEERING		
1287147	11/24/2025	11/13/2025	BROWN, JOEL	1.00	\$171.60	REGULAR	WRCCON	PRJ-13309-1-ENGINEERING		
			BROWN, JOEL Total		\$4,633.20					
1094845	11/25/2025	11/18/2025	POUSHO, ROBERT	8.00	\$501.60	REGULAR	WRCCON	PRJ-13309-1-INSPECTION		
1094845	11/25/2025	11/20/2025	POUSHO, ROBERT	8.00	\$501.60	REGULAR	WRCCON	PRJ-13309-1-INSPECTION		
1094845	11/25/2025	11/25/2025	POUSHO, ROBERT	8.00	\$501.60	REGULAR	WRCCON	PRJ-13309-1-INSPECTION		
1094845	11/12/2025	11/6/2025	POUSHO, ROBERT	8.00	\$501.60	REGULAR	WRCCON	PRJ-13309-1-INSPECTION		
1094845	11/12/2025	11/11/2025	POUSHO, ROBERT	8.00	\$501.60	REGULAR	WRCCON	PRJ-13309-1-INSPECTION		
1094845	11/12/2025	11/13/2025	POUSHO, ROBERT	8.00	\$501.60	REGULAR	WRCCON	PRJ-13309-1-INSPECTION		
			POUSHO, ROBERT Total		\$3,009.60					
1131289	11/5/2025	10/20/2025	PUSCAS, JACK J	0.50	\$58.06	OVERTIME	WRCADM	PRJ-13309-1-ENGINEERING		
1131289	11/19/2025	11/7/2025	PUSCAS, JACK J	3.00	\$319.29	REGULAR	WRCADM	PRJ-13309-1-ENGINEERING		
1131289	11/5/2025	10/20/2025	PUSCAS, JACK J	1.00	\$106.43	REGULAR	WRCADM	PRJ-13309-1-ENGINEERING		
			PUSCAS, JACK J Total		\$483.78					
1255122	11/25/2025	11/25/2025	ROBERTOY, KATY	2.00	\$148.24	REGULAR	WRCCON	PRJ-13309-1-ADMINISTRATION		
1255122	11/20/2025	11/20/2025	ROBERTOY, KATY	4.00	\$296.48	REGULAR	WRCCON	PRJ-13309-1-ADMINISTRATION		
1255122	11/6/2025	11/5/2025	ROBERTOY, KATY	2.00	\$148.24	REGULAR	WRCCON	PRJ-13309-1-ADMINISTRATION		
1255122	11/4/2025	11/4/2025	ROBERTOY, KATY	2.00	\$148.24	REGULAR	WRCCON	PRJ-13309-1-ADMINISTRATION		
1255122	11/12/2025	11/7/2025	ROBERTOY, KATY	4.00	\$296.48	REGULAR	WRCCON	PRJ-13309-1-ADMINISTRATION		
			ROBERTOY, KATY Total		\$1,037.68					
			Grand Total		\$9,164.26					

OMI Segment 5 NESP Mech - Elect Construction Project - WRC Labor/Fringes/Non-Direct Labor Factor for Trans Dates -								11/1/2025	11/28/2025
WOID	Date Entered	Date Worked	Name/Description	Hours/Units	Cost	Cost Category	Assign Equipment	Project	Activity
1287147	11/24/2025	10/6/2025	BROWN, JOEL	1.00	\$0.40	ASSIGNED	Cell Phone	PRJ-13309-1-ENGINEERING	
1287147	11/24/2025	10/8/2025	BROWN, JOEL	1.00	\$0.40	ASSIGNED	Cell Phone	PRJ-13309-1-ENGINEERING	
1287147	11/24/2025	10/9/2025	BROWN, JOEL	1.00	\$0.40	ASSIGNED	Cell Phone	PRJ-13309-1-ENGINEERING	
1287147	11/24/2025	10/10/2025	BROWN, JOEL	2.50	\$1.00	ASSIGNED	Cell Phone	PRJ-13309-1-ENGINEERING	
1287147	11/24/2025	10/13/2025	BROWN, JOEL	1.00	\$0.40	ASSIGNED	Cell Phone	PRJ-13309-1-ENGINEERING	
1287147	11/24/2025	10/14/2025	BROWN, JOEL	4.00	\$1.60	ASSIGNED	Cell Phone	PRJ-13309-1-ENGINEERING	
1287147	11/24/2025	10/15/2025	BROWN, JOEL	3.00	\$1.20	ASSIGNED	Cell Phone	PRJ-13309-1-ENGINEERING	
1287147	11/24/2025	10/20/2025	BROWN, JOEL	3.00	\$1.20	ASSIGNED	Cell Phone	PRJ-13309-1-ENGINEERING	
1287147	11/24/2025	10/24/2025	BROWN, JOEL	0.50	\$0.20	ASSIGNED	Cell Phone	PRJ-13309-1-ENGINEERING	
1287147	11/24/2025	10/27/2025	BROWN, JOEL	1.00	\$0.40	ASSIGNED	Cell Phone	PRJ-13309-1-ENGINEERING	
1287147	11/24/2025	10/28/2025	BROWN, JOEL	1.00	\$0.40	ASSIGNED	Cell Phone	PRJ-13309-1-ENGINEERING	
1287147	11/24/2025	10/29/2025	BROWN, JOEL	1.00	\$0.40	ASSIGNED	Cell Phone	PRJ-13309-1-ENGINEERING	
1287147	11/24/2025	10/30/2025	BROWN, JOEL	2.00	\$0.80	ASSIGNED	Cell Phone	PRJ-13309-1-ENGINEERING	
1287147	11/24/2025	10/31/2025	BROWN, JOEL	4.00	\$1.60	ASSIGNED	Cell Phone	PRJ-13309-1-ENGINEERING	
1287147	11/24/2025	11/13/2025	BROWN, JOEL	1.00	\$0.40	ASSIGNED	Cell Phone	PRJ-13309-1-ENGINEERING	
1287147	11/24/2025	10/6/2025	BROWN, JOEL	1.00	\$2.34	ASSIGNED	PC/Computer	PRJ-13309-1-ENGINEERING	
1287147	11/24/2025	10/8/2025	BROWN, JOEL	1.00	\$2.34	ASSIGNED	PC/Computer	PRJ-13309-1-ENGINEERING	
1287147	11/24/2025	10/9/2025	BROWN, JOEL	1.00	\$2.34	ASSIGNED	PC/Computer	PRJ-13309-1-ENGINEERING	
1287147	11/24/2025	10/10/2025	BROWN, JOEL	2.50	\$5.85	ASSIGNED	PC/Computer	PRJ-13309-1-ENGINEERING	
1287147	11/24/2025	10/13/2025	BROWN, JOEL	1.00	\$2.34	ASSIGNED	PC/Computer	PRJ-13309-1-ENGINEERING	
1287147	11/24/2025	10/14/2025	BROWN, JOEL	4.00	\$9.36	ASSIGNED	PC/Computer	PRJ-13309-1-ENGINEERING	
1287147	11/24/2025	10/15/2025	BROWN, JOEL	3.00	\$7.02	ASSIGNED	PC/Computer	PRJ-13309-1-ENGINEERING	
1287147	11/24/2025	10/20/2025	BROWN, JOEL	3.00	\$7.02	ASSIGNED	PC/Computer	PRJ-13309-1-ENGINEERING	
1287147	11/24/2025	10/24/2025	BROWN, JOEL	0.50	\$1.17	ASSIGNED	PC/Computer	PRJ-13309-1-ENGINEERING	
1287147	11/24/2025	10/27/2025	BROWN, JOEL	1.00	\$2.34	ASSIGNED	PC/Computer	PRJ-13309-1-ENGINEERING	
1287147	11/24/2025	10/28/2025	BROWN, JOEL	1.00	\$2.34	ASSIGNED	PC/Computer	PRJ-13309-1-ENGINEERING	
1287147	11/24/2025	10/29/2025	BROWN, JOEL	1.00	\$2.34	ASSIGNED	PC/Computer	PRJ-13309-1-ENGINEERING	
1287147	11/24/2025	10/30/2025	BROWN, JOEL	2.00	\$4.68	ASSIGNED	PC/Computer	PRJ-13309-1-ENGINEERING	
1287147	11/24/2025	10/31/2025	BROWN, JOEL	4.00	\$9.36	ASSIGNED	PC/Computer	PRJ-13309-1-ENGINEERING	
1287147	11/24/2025	11/13/2025	BROWN, JOEL	1.00	\$2.34	ASSIGNED	PC/Computer	PRJ-13309-1-ENGINEERING	
1287147	11/24/2025	10/6/2025	BROWN, JOEL	1.00	\$0.25	ASSIGNED	Tablet/iPad	PRJ-13309-1-ENGINEERING	
1287147	11/24/2025	10/8/2025	BROWN, JOEL	1.00	\$0.25	ASSIGNED	Tablet/iPad	PRJ-13309-1-ENGINEERING	
1287147	11/24/2025	10/9/2025	BROWN, JOEL	1.00	\$0.25	ASSIGNED	Tablet/iPad	PRJ-13309-1-ENGINEERING	
1287147	11/24/2025	10/10/2025	BROWN, JOEL	2.50	\$0.63	ASSIGNED	Tablet/iPad	PRJ-13309-1-ENGINEERING	
1287147	11/24/2025	10/13/2025	BROWN, JOEL	1.00	\$0.25	ASSIGNED	Tablet/iPad	PRJ-13309-1-ENGINEERING	
1287147	11/24/2025	10/14/2025	BROWN, JOEL	4.00	\$1.00	ASSIGNED	Tablet/iPad	PRJ-13309-1-ENGINEERING	
1287147	11/24/2025	10/15/2025	BROWN, JOEL	3.00	\$0.75	ASSIGNED	Tablet/iPad	PRJ-13309-1-ENGINEERING	
1287147	11/24/2025	10/20/2025	BROWN, JOEL	3.00	\$0.75	ASSIGNED	Tablet/iPad	PRJ-13309-1-ENGINEERING	
1287147	11/24/2025	10/24/2025	BROWN, JOEL	0.50	\$0.13	ASSIGNED	Tablet/iPad	PRJ-13309-1-ENGINEERING	
1287147	11/24/2025	10/27/2025	BROWN, JOEL	1.00	\$0.25	ASSIGNED	Tablet/iPad	PRJ-13309-1-ENGINEERING	
1287147	11/24/2025	10/28/2025	BROWN, JOEL	1.00	\$0.25	ASSIGNED	Tablet/iPad	PRJ-13309-1-ENGINEERING	
1287147	11/24/2025	10/29/2025	BROWN, JOEL	1.00	\$0.25	ASSIGNED	Tablet/iPad	PRJ-13309-1-ENGINEERING	
1287147	11/24/2025	10/30/2025	BROWN, JOEL	2.00	\$0.50	ASSIGNED	Tablet/iPad	PRJ-13309-1-ENGINEERING	
1287147	11/24/2025	10/31/2025	BROWN, JOEL	4.00	\$1.00	ASSIGNED	Tablet/iPad	PRJ-13309-1-ENGINEERING	
1287147	11/24/2025	11/13/2025	BROWN, JOEL	1.00	\$0.25	ASSIGNED	Tablet/iPad	PRJ-13309-1-ENGINEERING	
			BROWN, JOEL Total		\$80.74				
1094845	11/12/2025	11/6/2025	POUSHO, ROBERT	8.00	\$3.20	ASSIGNED	Cell Phone	PRJ-13309-1-INSPECTION	
1094845	11/12/2025	11/11/2025	POUSHO, ROBERT	8.00	\$3.20	ASSIGNED	Cell Phone	PRJ-13309-1-INSPECTION	
1094845	11/12/2025	11/13/2025	POUSHO, ROBERT	8.00	\$3.20	ASSIGNED	Cell Phone	PRJ-13309-1-INSPECTION	
1094845	11/25/2025	11/18/2025	POUSHO, ROBERT	8.00	\$3.20	ASSIGNED	Cell Phone	PRJ-13309-1-INSPECTION	
1094845	11/25/2025	11/20/2025	POUSHO, ROBERT	8.00	\$3.20	ASSIGNED	Cell Phone	PRJ-13309-1-INSPECTION	
1094845	11/25/2025	11/25/2025	POUSHO, ROBERT	8.00	\$3.20	ASSIGNED	Cell Phone	PRJ-13309-1-INSPECTION	
1094845	11/12/2025	11/6/2025	POUSHO, ROBERT	8.00	\$18.72	ASSIGNED	PC/Computer	PRJ-13309-1-INSPECTION	
1094845	11/12/2025	11/11/2025	POUSHO, ROBERT	8.00	\$18.72	ASSIGNED	PC/Computer	PRJ-13309-1-INSPECTION	
1094845	11/12/2025	11/13/2025	POUSHO, ROBERT	8.00	\$18.72	ASSIGNED	PC/Computer	PRJ-13309-1-INSPECTION	
1094845	11/25/2025	11/18/2025	POUSHO, ROBERT	8.00	\$18.72	ASSIGNED	PC/Computer	PRJ-13309-1-INSPECTION	
1094845	11/25/2025	11/20/2025	POUSHO, ROBERT	8.00	\$18.72	ASSIGNED	PC/Computer	PRJ-13309-1-INSPECTION	
1094845	11/25/2025	11/25/2025	POUSHO, ROBERT	8.00	\$18.72	ASSIGNED	PC/Computer	PRJ-13309-1-INSPECTION	
			POUSHO, ROBERT Total		\$131.52				
1131289	11/19/2025	11/7/2025	PUSCAS, JACK J	3.00	\$1.20	ASSIGNED	Cell Phone	PRJ-13309-1-ENGINEERING	
1131289	11/5/2025	10/20/2025	PUSCAS, JACK J	1.00	\$0.40	ASSIGNED	Cell Phone	PRJ-13309-1-ENGINEERING	
1131289	11/5/2025	10/20/2025	PUSCAS, JACK J	0.50	\$0.20	ASSIGNED	Cell Phone	PRJ-13309-1-ENGINEERING	
1131289	11/19/2025	11/7/2025	PUSCAS, JACK J	3.00	\$7.02	ASSIGNED	PC/Computer	PRJ-13309-1-ENGINEERING	
1131289	11/5/2025	10/20/2025	PUSCAS, JACK J	1.00	\$2.34	ASSIGNED	PC/Computer	PRJ-13309-1-ENGINEERING	
1131289	11/5/2025	10/20/2025	PUSCAS, JACK J	0.50	\$1.17	ASSIGNED	PC/Computer	PRJ-13309-1-ENGINEERING	
			PUSCAS, JACK J Total		\$12.33				

OMI Segment 5 NESP Mech - Elect Construction Project - WRC Labor/Fringes/Non-Direct Labor Factor for Trans Dates -								11/1/2025	-	11/28/2025
1255122	11/20/2025	11/20/2025	ROBERTOY, KATY	4.00	\$1.60	ASSIGNED	Cell Phone	PRJ-13309-1-ADMINISTRATION		
1255122	11/4/2025	11/4/2025	ROBERTOY, KATY	2.00	\$0.80	ASSIGNED	Cell Phone	PRJ-13309-1-ADMINISTRATION		
1255122	11/6/2025	11/5/2025	ROBERTOY, KATY	2.00	\$0.80	ASSIGNED	Cell Phone	PRJ-13309-1-ADMINISTRATION		
1255122	11/12/2025	11/7/2025	ROBERTOY, KATY	4.00	\$1.60	ASSIGNED	Cell Phone	PRJ-13309-1-ADMINISTRATION		
1255122	11/25/2025	11/25/2025	ROBERTOY, KATY	2.00	\$0.80	ASSIGNED	Cell Phone	PRJ-13309-1-ADMINISTRATION		
1255122	11/20/2025	11/20/2025	ROBERTOY, KATY	4.00	\$9.36	ASSIGNED	PC/Computer	PRJ-13309-1-ADMINISTRATION		
1255122	11/4/2025	11/4/2025	ROBERTOY, KATY	2.00	\$4.68	ASSIGNED	PC/Computer	PRJ-13309-1-ADMINISTRATION		
1255122	11/6/2025	11/5/2025	ROBERTOY, KATY	2.00	\$4.68	ASSIGNED	PC/Computer	PRJ-13309-1-ADMINISTRATION		
1255122	11/12/2025	11/7/2025	ROBERTOY, KATY	4.00	\$9.36	ASSIGNED	PC/Computer	PRJ-13309-1-ADMINISTRATION		
1255122	11/25/2025	11/25/2025	ROBERTOY, KATY	2.00	\$4.68	ASSIGNED	PC/Computer	PRJ-13309-1-ADMINISTRATION		
1255122	11/20/2025	11/20/2025	ROBERTOY, KATY	4.00	\$1.00	ASSIGNED	Tablet/iPad	PRJ-13309-1-ADMINISTRATION		
1255122	11/4/2025	11/4/2025	ROBERTOY, KATY	2.00	\$0.50	ASSIGNED	Tablet/iPad	PRJ-13309-1-ADMINISTRATION		
1255122	11/6/2025	11/5/2025	ROBERTOY, KATY	2.00	\$0.50	ASSIGNED	Tablet/iPad	PRJ-13309-1-ADMINISTRATION		
1255122	11/12/2025	11/7/2025	ROBERTOY, KATY	4.00	\$1.00	ASSIGNED	Tablet/iPad	PRJ-13309-1-ADMINISTRATION		
1255122	11/25/2025	11/25/2025	ROBERTOY, KATY	2.00	\$0.50	ASSIGNED	Tablet/iPad	PRJ-13309-1-ADMINISTRATION		
			ROBERTOY, KATY Total		\$41.86					
			Grand Total		\$266.45					

OMI Segment 5 NI-EA Construction Project - WRC Labor/Fringes/Non-Direct Labor Factor for Trans Dates -								11/1/2025	-	11/28/2025
WOID	Date Entered	Date Worked	Name/Description	Hours/Units	Cost	Cost Category	Assign Equipment	Project	Activity	
1300925	11/25/2025	11/25/2025	ROBERTOY, KATY	4.00	\$296.48	REGULAR	WRCCON	PRJ-13308-1-ADMINISTRATION		
			ROBERTOY, KATY Total		\$296.48					
			Grand Total		\$296.48					

OMI Segment 5 NI-EA Construction Project - WRC Labor/Fringes/Non-Direct Labor Factor for Trans Dates -								11/1/2025	-	11/28/2025
WOID	Date Entered	Date Worked	Name/Description	Hours/Units	Cost	Cost Category	Assign Equipment	Project	Activity	
1300925	11/25/2025	11/25/2025	ROBERTOY, KATY	4.00	\$1.60	ASSIGNED	Cell Phone	PRJ-13308-1-ADMINISTRATION		
1300925	11/25/2025	11/25/2025	ROBERTOY, KATY	4.00	\$9.36	ASSIGNED	PC/Computer	PRJ-13308-1-ADMINISTRATION		
1300925	11/25/2025	11/25/2025	ROBERTOY, KATY	4.00	\$1.00	ASSIGNED	Tablet/iPad	PRJ-13308-1-ADMINISTRATION		
			ROBERTOY, KATY Total		\$11.96					
			Grand Total		\$11.96					

OMI Odor & Corrosion Construction Project - WRC Labor/Fringes/Non-Direct Labor Factor for Trans Dates -								11/1/2025	-	11/28/2025
WOID	Date Entered	Date Worked	Name/Description	Hours/Units	Cost	Cost Category	Assign Equipment	Project		Activity
1285827	11/14/2025	11/13/2025	CARLEY, JOSEPH	1.00	\$104.79	REGULAR	WRCCDM	PRJ-17705-1-INSPECTION		
1285827	11/14/2025	11/14/2025	CARLEY, JOSEPH	1.00	\$104.79	REGULAR	WRCCDM	PRJ-17705-1-INSPECTION		
			CARLEY, JOSEPH Total		\$209.58					
1286152	11/4/2025	10/30/2025	COOK, JENNIFER	4.00	\$540.88	REGULAR	WRCADM	PRJ-17705-1-ENGINEERING		
1286152	11/4/2025	10/31/2025	COOK, JENNIFER	2.00	\$270.44	REGULAR	WRCADM	PRJ-17705-1-ENGINEERING		
1286152	11/4/2025	10/21/2025	COOK, JENNIFER	1.00	\$135.22	REGULAR	WRCADM	PRJ-17705-1-ENGINEERING		
1286152	11/4/2025	10/22/2025	COOK, JENNIFER	1.00	\$135.22	REGULAR	WRCADM	PRJ-17705-1-ENGINEERING		
1286152	11/4/2025	10/23/2025	COOK, JENNIFER	2.00	\$270.44	REGULAR	WRCADM	PRJ-17705-1-ENGINEERING		
1286152	11/4/2025	10/24/2025	COOK, JENNIFER	2.00	\$270.44	REGULAR	WRCADM	PRJ-17705-1-ENGINEERING		
1286152	11/4/2025	10/27/2025	COOK, JENNIFER	2.00	\$270.44	REGULAR	WRCADM	PRJ-17705-1-ENGINEERING		
1286152	11/4/2025	10/29/2025	COOK, JENNIFER	2.00	\$270.44	REGULAR	WRCADM	PRJ-17705-1-ENGINEERING		
1286152	11/18/2025	11/7/2025	COOK, JENNIFER	2.00	\$270.44	REGULAR	WRCADM	PRJ-17705-1-ENGINEERING		
1286152	11/18/2025	11/10/2025	COOK, JENNIFER	2.00	\$270.44	REGULAR	WRCADM	PRJ-17705-1-ENGINEERING		
1286152	11/18/2025	11/12/2025	COOK, JENNIFER	2.00	\$270.44	REGULAR	WRCADM	PRJ-17705-1-ENGINEERING		
1286152	11/18/2025	11/14/2025	COOK, JENNIFER	2.00	\$270.44	REGULAR	WRCADM	PRJ-17705-1-ENGINEERING		
1286152	11/18/2025	11/3/2025	COOK, JENNIFER	2.00	\$270.44	REGULAR	WRCADM	PRJ-17705-1-ENGINEERING		
1286152	11/18/2025	11/4/2025	COOK, JENNIFER	3.00	\$405.66	REGULAR	WRCADM	PRJ-17705-1-ENGINEERING		
1286152	11/18/2025	11/5/2025	COOK, JENNIFER	2.00	\$270.44	REGULAR	WRCADM	PRJ-17705-1-ENGINEERING		
1286152	11/18/2025	11/6/2025	COOK, JENNIFER	2.00	\$270.44	REGULAR	WRCADM	PRJ-17705-1-ENGINEERING		
			COOK, JENNIFER Total		\$4,462.26					
1285827	11/25/2025	11/24/2025	KOTAJARVI, KYLE A	1.00	\$85.31	OVERTIME	WRCCDM	PRJ-17705-1-INSPECTION		
1285827	11/7/2025	11/6/2025	KOTAJARVI, KYLE A	1.00	\$85.31	OVERTIME	WRCCDM	PRJ-17705-1-INSPECTION		
1285827	11/6/2025	11/5/2025	KOTAJARVI, KYLE A	0.50	\$42.66	OVERTIME	WRCCDM	PRJ-17705-1-INSPECTION		
1285827	11/6/2025	11/3/2025	KOTAJARVI, KYLE A	1.00	\$85.31	OVERTIME	WRCCDM	PRJ-17705-1-INSPECTION		
1285827	11/18/2025	11/17/2025	KOTAJARVI, KYLE A	0.50	\$42.66	OVERTIME	WRCCDM	PRJ-17705-1-INSPECTION		
1285827	11/21/2025	11/21/2025	KOTAJARVI, KYLE A	0.50	\$42.66	OVERTIME	WRCCDM	PRJ-17705-1-INSPECTION		
1285827	11/21/2025	11/20/2025	KOTAJARVI, KYLE A	0.50	\$42.66	OVERTIME	WRCCDM	PRJ-17705-1-INSPECTION		
1285827	11/21/2025	11/18/2025	KOTAJARVI, KYLE A	0.50	\$42.66	OVERTIME	WRCCDM	PRJ-17705-1-INSPECTION		
1285827	11/21/2025	11/19/2025	KOTAJARVI, KYLE A	0.50	\$42.66	OVERTIME	WRCCDM	PRJ-17705-1-INSPECTION		
1285827	11/21/2025	11/20/2025	KOTAJARVI, KYLE A	8.00	\$625.60	REGULAR	WRCCDM	PRJ-17705-1-INSPECTION		
1285827	11/25/2025	11/24/2025	KOTAJARVI, KYLE A	8.00	\$625.60	REGULAR	WRCCDM	PRJ-17705-1-INSPECTION		
1285827	11/21/2025	11/19/2025	KOTAJARVI, KYLE A	8.00	\$625.60	REGULAR	WRCCDM	PRJ-17705-1-INSPECTION		
1285827	11/21/2025	11/21/2025	KOTAJARVI, KYLE A	8.00	\$625.60	REGULAR	WRCCDM	PRJ-17705-1-INSPECTION		
1285827	11/18/2025	11/18/2025	KOTAJARVI, KYLE A	8.00	\$625.60	REGULAR	WRCCDM	PRJ-17705-1-INSPECTION		
1285827	11/6/2025	11/5/2025	KOTAJARVI, KYLE A	8.00	\$625.60	REGULAR	WRCCDM	PRJ-17705-1-INSPECTION		
1285827	11/6/2025	11/6/2025	KOTAJARVI, KYLE A	8.00	\$625.60	REGULAR	WRCCDM	PRJ-17705-1-INSPECTION		
1285827	11/18/2025	11/13/2025	KOTAJARVI, KYLE A	8.00	\$625.60	REGULAR	WRCCDM	PRJ-17705-1-INSPECTION		
1285827	11/18/2025	11/17/2025	KOTAJARVI, KYLE A	8.00	\$625.60	REGULAR	WRCCDM	PRJ-17705-1-INSPECTION		
1285827	11/7/2025	11/7/2025	KOTAJARVI, KYLE A	8.00	\$625.60	REGULAR	WRCCDM	PRJ-17705-1-INSPECTION		
1285827	11/6/2025	11/3/2025	KOTAJARVI, KYLE A	8.00	\$625.60	REGULAR	WRCCDM	PRJ-17705-1-INSPECTION		
1285827	11/12/2025	11/10/2025	KOTAJARVI, KYLE A	8.00	\$625.60	REGULAR	WRCCDM	PRJ-17705-1-INSPECTION		
1285827	11/12/2025	11/12/2025	KOTAJARVI, KYLE A	8.00	\$625.60	REGULAR	WRCCDM	PRJ-17705-1-INSPECTION		
1285827	11/25/2025	11/25/2025	KOTAJARVI, KYLE A	5.00	\$391.00	REGULAR	WRCCDM	PRJ-17705-1-INSPECTION		
1285827	11/26/2025	11/26/2025	KOTAJARVI, KYLE A	8.00	\$625.60	REGULAR	WRCCDM	PRJ-17705-1-INSPECTION		
			KOTAJARVI, KYLE A Total		\$9,661.29					
1348187	11/20/2025	11/20/2025	ROBERTOY, KATY	4.00	\$296.48	REGULAR	WRCCON	PRJ-17705-1-ADMINISTRATION		
1348187	11/4/2025	11/4/2025	ROBERTOY, KATY	2.00	\$148.24	REGULAR	WRCCON	PRJ-17705-1-ADMINISTRATION		
			ROBERTOY, KATY Total		\$444.72					
			Grand Total		\$14,777.85					

OMI Odor & Corrosion Construction Project - WRC Labor/Fringes/Non-Direct Labor Factor for Trans Dates -								11/1/2025	11/28/2025
WOID	Date Entered	Date Worked	Name/Description	Hours/Units	Cost	Cost Category	Assign Equipment	Project	Activity
1285827	11/14/2025	11/13/2025	CARLEY, JOSEPH	1.00	\$5.69	ASSIGNED	1/2 Ton Pick-up	PRJ-17705-1-INSPECTION	
1285827	11/14/2025	11/14/2025	CARLEY, JOSEPH	1.00	\$5.69	ASSIGNED	1/2 Ton Pick-up	PRJ-17705-1-INSPECTION	
1285827	11/14/2025	11/13/2025	CARLEY, JOSEPH	1.00	\$0.40	ASSIGNED	Cell Phone	PRJ-17705-1-INSPECTION	
1285827	11/14/2025	11/14/2025	CARLEY, JOSEPH	1.00	\$0.40	ASSIGNED	Cell Phone	PRJ-17705-1-INSPECTION	
1285827	11/14/2025	11/13/2025	CARLEY, JOSEPH	1.00	\$2.34	ASSIGNED	PC/Computer	PRJ-17705-1-INSPECTION	
1285827	11/14/2025	11/14/2025	CARLEY, JOSEPH	1.00	\$2.34	ASSIGNED	PC/Computer	PRJ-17705-1-INSPECTION	
			CARLEY, JOSEPH Total		\$16.86				
1286152	11/18/2025	11/3/2025	COOK, JENNIFER	2.00	\$0.80	ASSIGNED	Cell Phone	PRJ-17705-1-ENGINEERING	
1286152	11/18/2025	11/4/2025	COOK, JENNIFER	3.00	\$1.20	ASSIGNED	Cell Phone	PRJ-17705-1-ENGINEERING	
1286152	11/18/2025	11/5/2025	COOK, JENNIFER	2.00	\$0.80	ASSIGNED	Cell Phone	PRJ-17705-1-ENGINEERING	
1286152	11/18/2025	11/6/2025	COOK, JENNIFER	2.00	\$0.80	ASSIGNED	Cell Phone	PRJ-17705-1-ENGINEERING	
1286152	11/18/2025	11/7/2025	COOK, JENNIFER	2.00	\$0.80	ASSIGNED	Cell Phone	PRJ-17705-1-ENGINEERING	
1286152	11/18/2025	11/10/2025	COOK, JENNIFER	2.00	\$0.80	ASSIGNED	Cell Phone	PRJ-17705-1-ENGINEERING	
1286152	11/18/2025	11/12/2025	COOK, JENNIFER	2.00	\$0.80	ASSIGNED	Cell Phone	PRJ-17705-1-ENGINEERING	
1286152	11/18/2025	11/14/2025	COOK, JENNIFER	2.00	\$0.80	ASSIGNED	Cell Phone	PRJ-17705-1-ENGINEERING	
1286152	11/4/2025	10/21/2025	COOK, JENNIFER	1.00	\$0.40	ASSIGNED	Cell Phone	PRJ-17705-1-ENGINEERING	
1286152	11/4/2025	10/22/2025	COOK, JENNIFER	1.00	\$0.40	ASSIGNED	Cell Phone	PRJ-17705-1-ENGINEERING	
1286152	11/4/2025	10/23/2025	COOK, JENNIFER	2.00	\$0.80	ASSIGNED	Cell Phone	PRJ-17705-1-ENGINEERING	
1286152	11/4/2025	10/24/2025	COOK, JENNIFER	2.00	\$0.80	ASSIGNED	Cell Phone	PRJ-17705-1-ENGINEERING	
1286152	11/4/2025	10/27/2025	COOK, JENNIFER	2.00	\$0.80	ASSIGNED	Cell Phone	PRJ-17705-1-ENGINEERING	
1286152	11/4/2025	10/29/2025	COOK, JENNIFER	2.00	\$0.80	ASSIGNED	Cell Phone	PRJ-17705-1-ENGINEERING	
1286152	11/4/2025	10/30/2025	COOK, JENNIFER	4.00	\$1.60	ASSIGNED	Cell Phone	PRJ-17705-1-ENGINEERING	
1286152	11/4/2025	10/31/2025	COOK, JENNIFER	2.00	\$0.80	ASSIGNED	Cell Phone	PRJ-17705-1-ENGINEERING	
1286152	11/18/2025	11/3/2025	COOK, JENNIFER	2.00	\$4.68	ASSIGNED	PC/Computer	PRJ-17705-1-ENGINEERING	
1286152	11/18/2025	11/4/2025	COOK, JENNIFER	3.00	\$7.02	ASSIGNED	PC/Computer	PRJ-17705-1-ENGINEERING	
1286152	11/18/2025	11/5/2025	COOK, JENNIFER	2.00	\$4.68	ASSIGNED	PC/Computer	PRJ-17705-1-ENGINEERING	
1286152	11/18/2025	11/6/2025	COOK, JENNIFER	2.00	\$4.68	ASSIGNED	PC/Computer	PRJ-17705-1-ENGINEERING	
1286152	11/18/2025	11/7/2025	COOK, JENNIFER	2.00	\$4.68	ASSIGNED	PC/Computer	PRJ-17705-1-ENGINEERING	
1286152	11/18/2025	11/10/2025	COOK, JENNIFER	2.00	\$4.68	ASSIGNED	PC/Computer	PRJ-17705-1-ENGINEERING	
1286152	11/18/2025	11/12/2025	COOK, JENNIFER	2.00	\$4.68	ASSIGNED	PC/Computer	PRJ-17705-1-ENGINEERING	
1286152	11/18/2025	11/14/2025	COOK, JENNIFER	2.00	\$4.68	ASSIGNED	PC/Computer	PRJ-17705-1-ENGINEERING	
1286152	11/4/2025	10/21/2025	COOK, JENNIFER	1.00	\$2.34	ASSIGNED	PC/Computer	PRJ-17705-1-ENGINEERING	
1286152	11/4/2025	10/22/2025	COOK, JENNIFER	1.00	\$2.34	ASSIGNED	PC/Computer	PRJ-17705-1-ENGINEERING	
1286152	11/4/2025	10/23/2025	COOK, JENNIFER	2.00	\$4.68	ASSIGNED	PC/Computer	PRJ-17705-1-ENGINEERING	
1286152	11/4/2025	10/24/2025	COOK, JENNIFER	2.00	\$4.68	ASSIGNED	PC/Computer	PRJ-17705-1-ENGINEERING	
1286152	11/4/2025	10/27/2025	COOK, JENNIFER	2.00	\$4.68	ASSIGNED	PC/Computer	PRJ-17705-1-ENGINEERING	
1286152	11/4/2025	10/29/2025	COOK, JENNIFER	2.00	\$4.68	ASSIGNED	PC/Computer	PRJ-17705-1-ENGINEERING	
1286152	11/4/2025	10/30/2025	COOK, JENNIFER	4.00	\$9.36	ASSIGNED	PC/Computer	PRJ-17705-1-ENGINEERING	
1286152	11/4/2025	10/31/2025	COOK, JENNIFER	2.00	\$4.68	ASSIGNED	PC/Computer	PRJ-17705-1-ENGINEERING	
			COOK, JENNIFER Total		\$90.42				
1285827	11/26/2025	11/26/2025	KOTAJARVI, KYLE A	8.00	\$45.52	ASSIGNED	1/2 Ton Pick-up	PRJ-17705-1-INSPECTION	
1285827	11/25/2025	11/24/2025	KOTAJARVI, KYLE A	8.00	\$45.52	ASSIGNED	1/2 Ton Pick-up	PRJ-17705-1-INSPECTION	
1285827	11/25/2025	11/24/2025	KOTAJARVI, KYLE A	1.00	\$5.69	ASSIGNED	1/2 Ton Pick-up	PRJ-17705-1-INSPECTION	
1285827	11/25/2025	11/25/2025	KOTAJARVI, KYLE A	5.00	\$28.45	ASSIGNED	1/2 Ton Pick-up	PRJ-17705-1-INSPECTION	
1285827	11/18/2025	11/13/2025	KOTAJARVI, KYLE A	8.00	\$45.52	ASSIGNED	1/2 Ton Pick-up	PRJ-17705-1-INSPECTION	
1285827	11/18/2025	11/17/2025	KOTAJARVI, KYLE A	8.00	\$45.52	ASSIGNED	1/2 Ton Pick-up	PRJ-17705-1-INSPECTION	
1285827	11/18/2025	11/17/2025	KOTAJARVI, KYLE A	0.50	\$2.85	ASSIGNED	1/2 Ton Pick-up	PRJ-17705-1-INSPECTION	
1285827	11/18/2025	11/18/2025	KOTAJARVI, KYLE A	8.00	\$45.52	ASSIGNED	1/2 Ton Pick-up	PRJ-17705-1-INSPECTION	
1285827	11/12/2025	11/10/2025	KOTAJARVI, KYLE A	8.00	\$45.52	ASSIGNED	1/2 Ton Pick-up	PRJ-17705-1-INSPECTION	
1285827	11/12/2025	11/12/2025	KOTAJARVI, KYLE A	8.00	\$45.52	ASSIGNED	1/2 Ton Pick-up	PRJ-17705-1-INSPECTION	
1285827	11/6/2025	11/3/2025	KOTAJARVI, KYLE A	8.00	\$45.52	ASSIGNED	1/2 Ton Pick-up	PRJ-17705-1-INSPECTION	
1285827	11/6/2025	11/3/2025	KOTAJARVI, KYLE A	1.00	\$5.69	ASSIGNED	1/2 Ton Pick-up	PRJ-17705-1-INSPECTION	
1285827	11/6/2025	11/5/2025	KOTAJARVI, KYLE A	8.00	\$45.52	ASSIGNED	1/2 Ton Pick-up	PRJ-17705-1-INSPECTION	
1285827	11/6/2025	11/5/2025	KOTAJARVI, KYLE A	0.50	\$2.85	ASSIGNED	1/2 Ton Pick-up	PRJ-17705-1-INSPECTION	
1285827	11/6/2025	11/6/2025	KOTAJARVI, KYLE A	8.00	\$45.52	ASSIGNED	1/2 Ton Pick-up	PRJ-17705-1-INSPECTION	
1285827	11/7/2025	11/6/2025	KOTAJARVI, KYLE A	1.00	\$5.69	ASSIGNED	1/2 Ton Pick-up	PRJ-17705-1-INSPECTION	
1285827	11/7/2025	11/7/2025	KOTAJARVI, KYLE A	8.00	\$45.52	ASSIGNED	1/2 Ton Pick-up	PRJ-17705-1-INSPECTION	
1285827	11/21/2025	11/18/2025	KOTAJARVI, KYLE A	0.50	\$2.85	ASSIGNED	1/2 Ton Pick-up	PRJ-17705-1-INSPECTION	
1285827	11/21/2025	11/19/2025	KOTAJARVI, KYLE A	8.00	\$45.52	ASSIGNED	1/2 Ton Pick-up	PRJ-17705-1-INSPECTION	
1285827	11/21/2025	11/19/2025	KOTAJARVI, KYLE A	0.50	\$2.85	ASSIGNED	1/2 Ton Pick-up	PRJ-17705-1-INSPECTION	
1285827	11/21/2025	11/20/2025	KOTAJARVI, KYLE A	8.00	\$45.52	ASSIGNED	1/2 Ton Pick-up	PRJ-17705-1-INSPECTION	
1285827	11/21/2025	11/20/2025	KOTAJARVI, KYLE A	0.50	\$2.85	ASSIGNED	1/2 Ton Pick-up	PRJ-17705-1-INSPECTION	
1285827	11/21/2025	11/21/2025	KOTAJARVI, KYLE A	8.00	\$45.52	ASSIGNED	1/2 Ton Pick-up	PRJ-17705-1-INSPECTION	
1285827	11/21/2025	11/21/2025	KOTAJARVI, KYLE A	0.50	\$2.85	ASSIGNED	1/2 Ton Pick-up	PRJ-17705-1-INSPECTION	
1285827	11/26/2025	11/26/2025	KOTAJARVI, KYLE A	8.00	\$3.20	ASSIGNED	Cell Phone	PRJ-17705-1-INSPECTION	
1285827	11/25/2025	11/24/2025	KOTAJARVI, KYLE A	8.00	\$3.20	ASSIGNED	Cell Phone	PRJ-17705-1-INSPECTION	
1285827	11/25/2025	11/24/2025	KOTAJARVI, KYLE A	1.00	\$0.40	ASSIGNED	Cell Phone	PRJ-17705-1-INSPECTION	
1285827	11/25/2025	11/25/2025	KOTAJARVI, KYLE A	5.00	\$2.00	ASSIGNED	Cell Phone	PRJ-17705-1-INSPECTION	
1285827	11/18/2025	11/13/2025	KOTAJARVI, KYLE A	8.00	\$3.20	ASSIGNED	Cell Phone	PRJ-17705-1-INSPECTION	

OMI Odor & Corrosion Construction Project - WRC Labor/Fringes/Non-Direct Labor Factor for Trans Dates -								11/1/2025	-	11/28/2025
1285827	11/18/2025	11/17/2025	KOTAJARVI, KYLE A	8.00	\$3.20	ASSIGNED	Cell Phone			PRJ-17705-1-INSPECTION
1285827	11/18/2025	11/17/2025	KOTAJARVI, KYLE A	0.50	\$0.20	ASSIGNED	Cell Phone			PRJ-17705-1-INSPECTION
1285827	11/18/2025	11/18/2025	KOTAJARVI, KYLE A	8.00	\$3.20	ASSIGNED	Cell Phone			PRJ-17705-1-INSPECTION
1285827	11/12/2025	11/10/2025	KOTAJARVI, KYLE A	8.00	\$3.20	ASSIGNED	Cell Phone			PRJ-17705-1-INSPECTION
1285827	11/12/2025	11/12/2025	KOTAJARVI, KYLE A	8.00	\$3.20	ASSIGNED	Cell Phone			PRJ-17705-1-INSPECTION
1285827	11/6/2025	11/3/2025	KOTAJARVI, KYLE A	8.00	\$3.20	ASSIGNED	Cell Phone			PRJ-17705-1-INSPECTION
1285827	11/6/2025	11/3/2025	KOTAJARVI, KYLE A	1.00	\$0.40	ASSIGNED	Cell Phone			PRJ-17705-1-INSPECTION
1285827	11/6/2025	11/5/2025	KOTAJARVI, KYLE A	8.00	\$3.20	ASSIGNED	Cell Phone			PRJ-17705-1-INSPECTION
1285827	11/6/2025	11/5/2025	KOTAJARVI, KYLE A	0.50	\$0.20	ASSIGNED	Cell Phone			PRJ-17705-1-INSPECTION
1285827	11/6/2025	11/6/2025	KOTAJARVI, KYLE A	8.00	\$3.20	ASSIGNED	Cell Phone			PRJ-17705-1-INSPECTION
1285827	11/7/2025	11/6/2025	KOTAJARVI, KYLE A	1.00	\$0.40	ASSIGNED	Cell Phone			PRJ-17705-1-INSPECTION
1285827	11/7/2025	11/7/2025	KOTAJARVI, KYLE A	8.00	\$3.20	ASSIGNED	Cell Phone			PRJ-17705-1-INSPECTION
1285827	11/21/2025	11/18/2025	KOTAJARVI, KYLE A	0.50	\$0.20	ASSIGNED	Cell Phone			PRJ-17705-1-INSPECTION
1285827	11/21/2025	11/19/2025	KOTAJARVI, KYLE A	8.00	\$3.20	ASSIGNED	Cell Phone			PRJ-17705-1-INSPECTION
1285827	11/21/2025	11/19/2025	KOTAJARVI, KYLE A	0.50	\$0.20	ASSIGNED	Cell Phone			PRJ-17705-1-INSPECTION
1285827	11/21/2025	11/20/2025	KOTAJARVI, KYLE A	8.00	\$3.20	ASSIGNED	Cell Phone			PRJ-17705-1-INSPECTION
1285827	11/21/2025	11/20/2025	KOTAJARVI, KYLE A	0.50	\$0.20	ASSIGNED	Cell Phone			PRJ-17705-1-INSPECTION
1285827	11/21/2025	11/21/2025	KOTAJARVI, KYLE A	8.00	\$3.20	ASSIGNED	Cell Phone			PRJ-17705-1-INSPECTION
1285827	11/21/2025	11/21/2025	KOTAJARVI, KYLE A	0.50	\$0.20	ASSIGNED	Cell Phone			PRJ-17705-1-INSPECTION
1285827	11/26/2025	11/26/2025	KOTAJARVI, KYLE A	8.00	\$18.72	ASSIGNED	PC/Computer			PRJ-17705-1-INSPECTION
1285827	11/25/2025	11/24/2025	KOTAJARVI, KYLE A	8.00	\$18.72	ASSIGNED	PC/Computer			PRJ-17705-1-INSPECTION
1285827	11/25/2025	11/24/2025	KOTAJARVI, KYLE A	1.00	\$2.34	ASSIGNED	PC/Computer			PRJ-17705-1-INSPECTION
1285827	11/25/2025	11/25/2025	KOTAJARVI, KYLE A	5.00	\$11.70	ASSIGNED	PC/Computer			PRJ-17705-1-INSPECTION
1285827	11/18/2025	11/13/2025	KOTAJARVI, KYLE A	8.00	\$18.72	ASSIGNED	PC/Computer			PRJ-17705-1-INSPECTION
1285827	11/18/2025	11/17/2025	KOTAJARVI, KYLE A	8.00	\$18.72	ASSIGNED	PC/Computer			PRJ-17705-1-INSPECTION
1285827	11/18/2025	11/17/2025	KOTAJARVI, KYLE A	0.50	\$1.17	ASSIGNED	PC/Computer			PRJ-17705-1-INSPECTION
1285827	11/18/2025	11/18/2025	KOTAJARVI, KYLE A	8.00	\$18.72	ASSIGNED	PC/Computer			PRJ-17705-1-INSPECTION
1285827	11/12/2025	11/10/2025	KOTAJARVI, KYLE A	8.00	\$18.72	ASSIGNED	PC/Computer			PRJ-17705-1-INSPECTION
1285827	11/12/2025	11/12/2025	KOTAJARVI, KYLE A	8.00	\$18.72	ASSIGNED	PC/Computer			PRJ-17705-1-INSPECTION
1285827	11/6/2025	11/3/2025	KOTAJARVI, KYLE A	8.00	\$18.72	ASSIGNED	PC/Computer			PRJ-17705-1-INSPECTION
1285827	11/6/2025	11/3/2025	KOTAJARVI, KYLE A	1.00	\$2.34	ASSIGNED	PC/Computer			PRJ-17705-1-INSPECTION
1285827	11/6/2025	11/5/2025	KOTAJARVI, KYLE A	8.00	\$18.72	ASSIGNED	PC/Computer			PRJ-17705-1-INSPECTION
1285827	11/6/2025	11/5/2025	KOTAJARVI, KYLE A	0.50	\$1.17	ASSIGNED	PC/Computer			PRJ-17705-1-INSPECTION
1285827	11/6/2025	11/6/2025	KOTAJARVI, KYLE A	8.00	\$18.72	ASSIGNED	PC/Computer			PRJ-17705-1-INSPECTION
1285827	11/7/2025	11/6/2025	KOTAJARVI, KYLE A	1.00	\$2.34	ASSIGNED	PC/Computer			PRJ-17705-1-INSPECTION
1285827	11/7/2025	11/7/2025	KOTAJARVI, KYLE A	8.00	\$18.72	ASSIGNED	PC/Computer			PRJ-17705-1-INSPECTION
1285827	11/21/2025	11/18/2025	KOTAJARVI, KYLE A	0.50	\$1.17	ASSIGNED	PC/Computer			PRJ-17705-1-INSPECTION
1285827	11/21/2025	11/19/2025	KOTAJARVI, KYLE A	8.00	\$18.72	ASSIGNED	PC/Computer			PRJ-17705-1-INSPECTION
1285827	11/21/2025	11/19/2025	KOTAJARVI, KYLE A	0.50	\$1.17	ASSIGNED	PC/Computer			PRJ-17705-1-INSPECTION
1285827	11/21/2025	11/20/2025	KOTAJARVI, KYLE A	8.00	\$18.72	ASSIGNED	PC/Computer			PRJ-17705-1-INSPECTION
1285827	11/21/2025	11/20/2025	KOTAJARVI, KYLE A	0.50	\$1.17	ASSIGNED	PC/Computer			PRJ-17705-1-INSPECTION
1285827	11/21/2025	11/21/2025	KOTAJARVI, KYLE A	8.00	\$18.72	ASSIGNED	PC/Computer			PRJ-17705-1-INSPECTION
1285827	11/21/2025	11/21/2025	KOTAJARVI, KYLE A	0.50	\$1.17	ASSIGNED	PC/Computer			PRJ-17705-1-INSPECTION
			KOTAJARVI, KYLE A Total		\$1,036.92					
1348187	11/20/2025	11/20/2025	ROBERTOY, KATY	4.00	\$1.60	ASSIGNED	Cell Phone			PRJ-17705-1-ADMINISTRATION
1348187	11/4/2025	11/4/2025	ROBERTOY, KATY	2.00	\$0.80	ASSIGNED	Cell Phone			PRJ-17705-1-ADMINISTRATION
1348187	11/20/2025	11/20/2025	ROBERTOY, KATY	4.00	\$9.36	ASSIGNED	PC/Computer			PRJ-17705-1-ADMINISTRATION
1348187	11/4/2025	11/4/2025	ROBERTOY, KATY	2.00	\$4.68	ASSIGNED	PC/Computer			PRJ-17705-1-ADMINISTRATION
1348187	11/20/2025	11/20/2025	ROBERTOY, KATY	4.00	\$1.00	ASSIGNED	Tablet/iPad			PRJ-17705-1-ADMINISTRATION
1348187	11/4/2025	11/4/2025	ROBERTOY, KATY	2.00	\$0.50	ASSIGNED	Tablet/iPad			PRJ-17705-1-ADMINISTRATION
			ROBERTOY, KATY Total		\$17.94					
			Grand Total		\$1,162.14					

NI-EA Contract #2 - Construction Project - WRC Labor/Fringes/Non-Direct Labor Factor for Trans Dates -								11/1/2025	-	11/28/2025
WOID	Date Entered	Date Worked	Name/Description	Hours/Units	Cost	Cost Category	Assign Equipment	Project	Activity	
1342844	11/25/2025	10/7/2025	BROWN, JOEL	1.00	\$171.60	REGULAR	WRCCON	PRJ-17408-1-ENGINEERING		
1342844	11/25/2025	10/9/2025	BROWN, JOEL	2.00	\$343.20	REGULAR	WRCCON	PRJ-17408-1-ENGINEERING		
1342844	11/25/2025	10/13/2025	BROWN, JOEL	1.00	\$171.60	REGULAR	WRCCON	PRJ-17408-1-ENGINEERING		
1342844	11/25/2025	10/20/2025	BROWN, JOEL	2.00	\$343.20	REGULAR	WRCCON	PRJ-17408-1-ENGINEERING		
1342844	11/25/2025	10/21/2025	BROWN, JOEL	1.00	\$171.60	REGULAR	WRCCON	PRJ-17408-1-ENGINEERING		
1342844	11/25/2025	10/27/2025	BROWN, JOEL	0.50	\$85.80	REGULAR	WRCCON	PRJ-17408-1-ENGINEERING		
1342844	11/25/2025	10/28/2025	BROWN, JOEL	1.00	\$171.60	REGULAR	WRCCON	PRJ-17408-1-ENGINEERING		
1342844	11/25/2025	10/30/2025	BROWN, JOEL	1.00	\$171.60	REGULAR	WRCCON	PRJ-17408-1-ENGINEERING		
1342844	11/25/2025	10/31/2025	BROWN, JOEL	2.00	\$343.20	REGULAR	WRCCON	PRJ-17408-1-ENGINEERING		
1342844	11/25/2025	11/10/2025	BROWN, JOEL	2.00	\$343.20	REGULAR	WRCCON	PRJ-17408-1-ENGINEERING		
			BROWN, JOEL Total		\$2,316.60					
1342844	11/4/2025	10/21/2025	COOK, JENNIFER	2.00	\$270.44	REGULAR	WRCADM	PRJ-17408-1-ENGINEERING		
1342844	11/4/2025	10/22/2025	COOK, JENNIFER	3.00	\$405.66	REGULAR	WRCADM	PRJ-17408-1-ENGINEERING		
1342844	11/4/2025	10/23/2025	COOK, JENNIFER	2.00	\$270.44	REGULAR	WRCADM	PRJ-17408-1-ENGINEERING		
1342844	11/4/2025	10/24/2025	COOK, JENNIFER	2.00	\$270.44	REGULAR	WRCADM	PRJ-17408-1-ENGINEERING		
1342844	11/4/2025	10/27/2025	COOK, JENNIFER	2.00	\$270.44	REGULAR	WRCADM	PRJ-17408-1-ENGINEERING		
1342844	11/4/2025	10/28/2025	COOK, JENNIFER	3.00	\$405.66	REGULAR	WRCADM	PRJ-17408-1-ENGINEERING		
1342844	11/4/2025	10/29/2025	COOK, JENNIFER	2.00	\$270.44	REGULAR	WRCADM	PRJ-17408-1-ENGINEERING		
1342844	11/4/2025	10/31/2025	COOK, JENNIFER	2.00	\$270.44	REGULAR	WRCADM	PRJ-17408-1-ENGINEERING		
1342844	11/18/2025	11/3/2025	COOK, JENNIFER	2.00	\$270.44	REGULAR	WRCADM	PRJ-17408-1-ENGINEERING		
1342844	11/18/2025	11/4/2025	COOK, JENNIFER	2.00	\$270.44	REGULAR	WRCADM	PRJ-17408-1-ENGINEERING		
1342844	11/18/2025	11/5/2025	COOK, JENNIFER	2.00	\$270.44	REGULAR	WRCADM	PRJ-17408-1-ENGINEERING		
1342844	11/18/2025	11/6/2025	COOK, JENNIFER	2.00	\$270.44	REGULAR	WRCADM	PRJ-17408-1-ENGINEERING		
1342844	11/18/2025	11/7/2025	COOK, JENNIFER	2.00	\$270.44	REGULAR	WRCADM	PRJ-17408-1-ENGINEERING		
1342844	11/18/2025	11/10/2025	COOK, JENNIFER	2.00	\$270.44	REGULAR	WRCADM	PRJ-17408-1-ENGINEERING		
1342844	11/18/2025	11/12/2025	COOK, JENNIFER	2.00	\$270.44	REGULAR	WRCADM	PRJ-17408-1-ENGINEERING		
1342844	11/18/2025	11/13/2025	COOK, JENNIFER	6.00	\$811.32	REGULAR	WRCADM	PRJ-17408-1-ENGINEERING		
1342844	11/18/2025	11/14/2025	COOK, JENNIFER	2.00	\$270.44	REGULAR	WRCADM	PRJ-17408-1-ENGINEERING		
			COOK, JENNIFER Total		\$5,408.80					
1343168	11/6/2025	11/5/2025	ROBERTOY, KATY	4.00	\$296.48	REGULAR	WRCCON	PRJ-17408-1-ADMINISTRATION		
			ROBERTOY, KATY Total		\$296.48					
			Grand Total		\$8,021.88					

1343168	11/6/2025	11/5/2025	ROBERTOY, KATY	4.00	\$1.60	ASSIGNED	Cell Phone	PRJ-17408-1-ADMINISTRATION
1343168	11/6/2025	11/5/2025	ROBERTOY, KATY	4.00	\$9.36	ASSIGNED	PC/Computer	PRJ-17408-1-ADMINISTRATION
1343168	11/6/2025	11/5/2025	ROBERTOY, KATY	4.00	\$1.00	ASSIGNED	Tablet/iPad	PRJ-17408-1-ADMINISTRATION
			ROBERTOY, KATY Total		\$11.96			
			Grand Total		\$161.93			



1235 Holden Ave
Milford, MI 48381
(248) 302-2078

CSM Mechanical - NESPS

82912 6010101 149090 730660 8637 Ch. 21

Bill To

OMIDD
One Public Works Drive, Building 95 West
Waterford, MI 48328 US

Invoice 6092

Nov 18, 2025

Job Number 4240
PO Number 01640
Payment Terms AIA 45

Total Due

\$470.00

Due Date

Jan 2, 2026

DBJ 2025/11/20

CUSTOMER NAME

OMIDD

PROPERTY NAME

OMIDD - Detroit NESPS- 11001

PROPERTY ADDRESS

11001 E State Fair Ave
Detroit, MI 48234

AUTHORIZED BY

CUSTOMER WO

NTE

Invoice Summary

Scope of Work:

1. Extend the air compressor drain pipe to reach the floor drain.
2. Install hard piping for the air compressor drain line on the pump floor.

Resolution:

The air compressor drain line was successfully extended and hard piped to the floor drain, ensuring proper drainage on the pump floor.

Item Name	Description	Quantity	Unit Price	Price Subtotal
Labor	Tyler Fields - November 14, 2025 - Labor	3	\$125.00	\$375.00
Vehicle / Tool Allowance	Vehicle / Tool Allowance	1	\$95.00	\$95.00
		4		\$470.00

Total \$470.00



Knowledgeable • Professional • Attentive • Likeable

29770 Hudson Drive Novi, MI 48377
Phone: (586) 978-7200
hesco-mi.com

Invoice No. 2019807-003

Date: 10/31/2025

Billed To: OMID Drainage District
1 Public Works Drive
Waterford MI 48328

Client ID: 669
Contract ID: WDCON11045
HESCO Project: 2019807S OMID Flow Control Structures

Contact: Terry Moore P.O.# WO #1611 Salesperson: Kevin Livingston Due Date: 11/30/2025

Description	Unit	Quantity	Price	Amount
Oil for storage Rando HD 22 - 481.64 Fuel surcharge - 0.75 + 14.95 handling fee Total - 497.34 + 15% upcharge materials	Each	1.00	571.94	571.94

Notes:

HESCO - NESPS					
82912	6010101	149090	730660	11045	Ch. 21

TM 11-10-25

ACH PAYMENTS:
HESCO GROUP LLC

Please note attachments
for change in bank details
and W-9.

ACH/EFT Remittance:
AR@hesco-mi.com

Remittance Checks To:
HESCO Group LLC
29770 Hudson Drive
Novi, MI 48377

Credit Card Payment:
Please call Receivables
1-586-978-7200 ext 101

A Service Charge of 4%
will be applied to all credit
card purchases.

Non-Taxable Amount:	0.00
Taxable Amount:	571.94
Sales Tax:	0.00
Total Invoice	571.94

Retention:	0.00
Payments/Credits:	0.00

Amount Due 571.94



PUMPING-REPAIR
FLOW CONTROL
PROCESS
AUTOMATION



INVOICE		
DATE	NUMBER	PAGE
7/14/2025	647319 b	1 of 1

B OMI100
I OAKLAND MACOMB INTERCEPTOR DRA
L 1 PUBLIC WORKS DR.
L SUBMIT INVOICES TO NEXGEN
T WATERFORD, MI 48328
O

S NORTH EAST PUMPING STATION
H 11001 E. STATE FAIR AVE
I DETROIT, MI 48234
P

Kennedy Industries - NESPS

82912 6010101 149090 730660 8643 Ch. 21

ATTENTION:

TERRY MOORE

313-8297207

TMOORE@METCOSERVICES.COM

CUSTOMER REF/PO #	JOB #	JOB TITLE	SLP	SHIPPING TYPE	TERMS
01537	0129562	GREAT LAKES WATER AUTHORITY, NEPS, FIELD SERVICE, SANITARY	SAH/CAG	FIELD SERVICE	NET 60

QUANTITY		PART NO.	DESCRIPTION	UNIT PRICE	EXTENDED
B/O	Ship				

0.00	1.00	GRE550NORTHEASTPS	GLWA, NORTHEAST PUMP STATION	\$4,781.38	\$4,781.38
------	------	-------------------	------------------------------	------------	------------

KENNEDY INDUSTRIES PROVIDED (2) FIELD SERVICE
TECHNICIANS ONSITE ON 07/09/2025.
PLEASE SEE THE ATTACHED SERVICE REPORT.

DBJ 2025/11/20

TOTAL REFLECTS THE BELOW:

(16) HOURS OF LABOR X \$173.00 = \$2,768.00

(7.25) HOURS OF LABOR OT X \$259.50 = \$1,881.38

MILEAGE: \$82.50

FUEL SURCHARGE: \$49.50

PLEASE REMIT TO:
KENNEDY INDUSTRIES, INC.
P.O. BOX 930079
WIXOM, MI 48393

This invoice is subject to and incorporates by reference Kennedy Industries, Inc.'s ("Kennedy") Terms & Conditions (Rev'd 6/2023) and Customer Warranty available at www.kennedyind.com which will be provided by email upon written request. Buyer expressly agrees to the provisions set forth in the Terms & Conditions and Customer Warranty posted on Kennedy's website

***TERMS OF PAYMENT ARE NET 30 DAYS FROM DATE OF INVOICE *A 7% PER ANNUM SERVICE CHARGE SHALL BE APPLIED TO ANY BALANCE *CREDIT CARD PAYMENTS ARE SUBJECT TO AN ADDITIONAL 3% CHARGE**

SUBTOTAL: \$4,781.38

TAX: \$ 0.00

TOTAL: \$4,781.38

P.O. Box 930079 Wixom, MI 48393 - 4925 Holtz Drive Wixom, MI 48393 - Phone: 248-684-1200 - Fax: 248-684-6011

www.KennedyInd.com



729 Meldrum, Detroit, MI 48207
Phone: (313) 568-1600 Fax: (313) 568-0488

Pay invoices online at www.lardnerelevator.com

INVOICE

205990

Bill To: 
Oakland Macomb Interceptor Drain Drainage District
1 Public Works Drive
dbgreen@metcoservices.com
tmoore@metcoservices.com
Waterford, MI 48328

Account: Northeast Pump Station
11001 E. State Fair
Detroit, MI 48234
Account #: 00-6642-2

Jul 21, 2025	Net 30 Days	Detroit Route	5739
205990	WO 01536	LECO	Repair

1.00	Quoted Price - #286 & 229	No	Each	14,998.00	\$14,998.00
<div style="border: 2px solid red; padding: 5px;"> <p>Lardner - NESPS</p> <p>82912 6010101 149090 730660 10510 Ch. 21</p> </div> <p><i>TM</i> 11-10-25</p>					
6/26 & 6/27/2025 TT# 206133 & 206134 E# 8944 Furnished and installed new roller guides. Recommendation: Needs CAT 5 Test.					
6/30/2025 TT# 206840 & 206841 E# 8944 Performed full load test.					
Quoted Job - #5739 Elevator Roller Guides WO 01536					
				\$0.00	
				\$14,998.00	
				\$14,998.00	
				\$0.00	
				\$14,998.00	

PLEASE DETACH THIS PORTION AND RETURN WITH PAYMENT



Lardner Elevator Company
729 Meldrum
Detroit, MI 48207

Account #	00-6642-2 Northeast Pump Station
Invoice #	205990
Amount	\$ 14,998.00
Paid	\$ <input type="text"/>



729 Meldrum, Detroit, MI 48207
Phone: (313) 568-1600 Fax: (313) 568-0488

Pay invoices online at www.lardnerelevator.com

INVOICE

206473

Bill To:
Oakland Macomb Interceptor Drain Drainage District
1 Public Works Drive
dbgreen@metcoservices.com
tmoore@metcoservices.com
Waterford, MI 48328

Account: Northeast Pump Station
11001 E. State Fair
Detroit, MI 48234
Account #: 00-6642-2

Sep 01, 2025	Upon Receipt	Detroit Route	4746
206473		LECO	Maintenance

Quantity	Description	Taxable	Unit	Rate	Total
1.00	Elevator Maintenance Service for September, 2025	No	Each	214.00	\$214.00
<div style="border: 2px solid red; padding: 5px;"> <p>Lardner - NESPS</p> <p>82912 6010101 149090 730660 10510 Ch. 21</p> <p style="text-align: center;"><i>TM</i> 11-10-25</p> </div>					
Elevator Maintenance Service for September, 2025					
					\$0.00
					\$214.00
					\$214.00
					\$0.00
					\$214.00

PLEASE DETACH THIS PORTION AND RETURN WITH PAYMENT



Lardner Elevator Company
729 Meldrum
Detroit, MI 48207

Account #	00-6642-2 Northeast Pump Station
Invoice #	206473
Amount	\$ 214.00
Paid	\$ <input type="text"/>



729 Meldrum, Detroit, MI 48207
Phone: (313) 568-1600 Fax: (313) 568-0488

Pay invoices online at www.lardnerelevator.com

INVOICE

206799

Bill To:
Oakland Macomb Interceptor Drain Drainage District
1 Public Works Drive
dbgreen@metcoservices.com
tmoore@metcoservices.com
Waterford, MI 48328

Account: Northeast Pump Station
11001 E. State Fair
Detroit, MI 48234
Account #: 00-6642-2

Oct 01,2025	Upon Receipt	Detroit Route	4746
206799		LECO	Maintenance

1.00	Elevator Maintenance Service for October, 2025	No	Each	214.00	\$214.00												
<table border="1"> <tr> <td colspan="6">Lardner - NESPS</td> </tr> <tr> <td>82912</td> <td>6010101</td> <td>149090</td> <td>730660</td> <td>10510</td> <td>Ch. 21</td> </tr> </table>						Lardner - NESPS						82912	6010101	149090	730660	10510	Ch. 21
Lardner - NESPS																	
82912	6010101	149090	730660	10510	Ch. 21												
<i>TM</i> 11-10-25																	
Elevator Maintenance Service for October, 2025																	
					\$0.00												
					\$214.00												
					\$214.00												
					\$0.00												
					\$214.00												

PLEASE DETACH THIS PORTION AND RETURN WITH PAYMENT



Lardner Elevator Company
729 Meldrum
Detroit, MI 48207

Account #	00-6642-2 Northeast Pump Station
Invoice #	206799
Amount	\$ 214.00
Paid	\$ <input type="text"/>



12835 Stephens Road · Warren · Michigan · 48089 · (586) 920-2620 · Fax (586) 510-4433

INVOICE NO. 1811-83

DATE: December 1, 2025

METCO PROJECT NO. 1811

INVOICE PERIOD: 11/03 thru 11/30/25

Contract ID 000000000000000000000000008448

Vendor ID 0000020486

TO: OMIDD

Water Resources Commissioner
 One Public Works Drive
 Waterford, MI 48328
 Attn: Joel Brown, P.E.
 Chief Engineer-Construction Projects Unit

TITLE: OMIDD & NESPS Operation and Maintenance

* Contractual Fees	Contract Amount	Engineering Work Order No. 2	Engineering Work Order No. 3	Engineering Work Order No. 4	Engineering Work Order No. 5	New Contract Amount	Amount Earned	Previous Invoices	Cumulative Total	Funds Remaining
Transition Plan	\$ 100,913.36	\$ -				\$ 100,913.36	\$ -	\$ 100,913.36	\$ 100,913.36	\$ -
3.1-3.4A-3.4B Operational Plan - Monthly Meetings-2021	\$ 262,620.00	\$ 211,858.00				\$ 474,478.00	\$ -	\$ 474,478.00	\$ 474,478.00	\$ -
3.1-3.4A-3.4B Operational Plan - Monthly Meetings-2022	\$ -	\$ 353,936.00				\$ 353,936.00	\$ -	\$ 353,936.00	\$ 353,936.00	\$ -
3.1-3.4A-3.4B Operational Plan - Monthly Meetings-2023	\$ -	\$ 318,436.00				\$ 318,436.00	\$ -	\$ 318,436.00	\$ 318,436.00	\$ -
3.3 Maintenance & Asset Management	\$ 78,906.64	\$ -				\$ 78,906.64	\$ -	\$ 162,073.04	\$ 162,073.04	\$ -
4.0 Operational Plan - Maintenance - Year 2	\$ 293,460.00	\$ -				\$ 293,460.00	\$ -	\$ 316,576.41	\$ 316,576.41	\$ -
Maintenance - 2021	\$ 293,460.00	\$ 263,044.80	\$ 286,680.00			\$ 843,184.80	\$ -	\$ 843,184.80	\$ 843,184.80	\$ -
Maintenance - 2022	\$ -	\$ 464,612.00	\$ 126,040.00			\$ 590,652.00	\$ -	\$ 590,652.00	\$ 590,652.00	\$ -
Maintenance - 2023	\$ -	\$ 323,112.80	\$ 243,884.60			\$ 566,997.40	\$ -	\$ 566,997.40	\$ 566,997.40	\$ -
Maintenance - 2024	\$ -	\$ -		\$ 929,278.12		\$ 929,278.12	\$ -	\$ 929,278.12	\$ 929,278.12	\$ -
Maintenance - 2025-2026	\$ -	\$ -		\$ 750,165.84	\$ 996,614.52	\$ 1,746,780.36	\$ 54,293.38	\$ 819,093.41	\$ 873,386.79	\$ 873,393.57
Maintenance - 2027					\$ 767,348.20	\$ 767,348.20		\$ -	\$ -	\$ 767,348.20
Maintenance - 2028					\$ 782,147.80	\$ 782,147.80		\$ -	\$ -	\$ 782,147.80
6.0 NEXGEN Asset Management Implementation Services	\$ 218,800.00	\$ -	\$ 295,628.60			\$ 514,428.60	\$ -	\$ 514,428.60	\$ 514,428.60	\$ -
12.0 As-Needed Services	\$ 205,000.00	\$ -			\$ 300,000.00	\$ 505,000.00	\$ 38,274.13	\$ 183,706.19	\$ 221,980.32	\$ 283,019.68
TOTAL	\$ 1,453,160.00	\$ 1,934,999.60	\$ 952,233.20	\$ 1,679,443.96	\$ 2,846,110.52	\$ 8,865,947.28	\$ 92,567.51	\$ 6,173,753.33	\$ 6,266,320.84	\$ 2,705,909.25



INVOICE NO. 1811-83

DATE: December 1, 2025

METCO PROJECT NO. 1811

INVOICE PERIOD: 11/03 thru 11/30/25

Contract ID 000000000000000000008448

Vendor ID 0000020486

TO: OMIDD

Water Resources Commissioner

One Public Works Drive

Waterford, MI 48328

Attn: Joel Brown, P.E.

Chief Engineer-Construction Projects Unit

TITLE: OMID & NESPS Operation and Maintenance

Operational Plan

OMID Operations - Fund 82912, Program 149130, Account 730373 (3.1-3.4A & 3.4B)

Name	Title	Hrs.	Rate/Hr.	Amount
Raj Vijayendran, PE	Principal Engineer	0.0	\$ 225.75	\$ -
Terry Moore	Operations Manager	22.0	\$ 162.00	\$ 3,564.00
Terry Moore	Operations Manager (Overt	0.0	\$ 204.75	\$ -
Darrin Green	Staff Engineer	36.0	\$ 102.00	\$ 3,672.00
Darrin Green	Staff Engineer-(Overtime)	0.0	\$ 153.00	\$ -
Anthony Vozza	Staff Engineer	68.0	\$ 102.00	\$ 6,936.00
Anthony Vozza	Staff Engineer-(Overtime)	8.0	\$ 153.00	\$ 1,224.00
Rosana Santos	Administrative Assoc.	0.0	\$ 73.79	\$ -
Subtotal OMID Operatons:				\$ 15,396.00

NEPS Operations - Fund 82912, Program 149090, Account 730373 (3.1-3.4A & 3.4B)

Name	Title	Hrs.	Rate/Hr.	Amount
Raj Vijayendran, PE	Principal Engineer	8.0	\$ 225.75	\$ 1,806.00
Terry Moore	Operations Manager	22.0	\$ 162.00	\$ 3,564.00
Terry Moore	Operations Manager (Overt	8.0	\$ 204.75	\$ 1,638.00
Darrin Green	Staff Engineer	36.0	\$ 102.00	\$ 3,672.00
Darrin Green	Staff Engineer-(Overtime)	0.0	\$ 153.00	\$ -
Anthony Vozza	Staff Engineer	0.0	\$ 102.00	\$ -
Anthony Vozza	Staff Engineer-(Overtime)	0.0	\$ 153.00	\$ -
Rosana Santos	Administrative Assoc.	4.0	\$ 77.48	\$ 309.92
Subtotal NEPS Operations				\$ 10,989.92

Subtotal Operations \$ 26,385.92

Maintenance & Asset Management

OMID Maintenance - Fund 82912, Program 149130, Account 730646 (3.2-3.3-3.4C & ALLOWANCE)

Name	Title	Hrs.	Rate/Hr.	Amount
Terry Moore	Operations Manager	22.0	\$ 162.00	\$ 3,564.00
Terry Moore	Operations Manager (Overt	0.0	\$ 204.75	\$ -
Daniel Martel	Sr. Project Coordinator	0.0	\$ 152.25	\$ -
Shailesh Patel	Sr. Project Engineer	0.0	\$ 152.25	\$ -
Anthony Vozza	Staff Engineer	0.0	\$ 102.00	\$ -
Anthony Vozza	Staff Engineer-(Overtime)	0.0	\$ 153.00	\$ -
Darrin Green	Staff Engineer	0.0	\$ 102.00	\$ -
Darrin Green	Staff Engineer-(Overtime)	0.0	\$ 153.00	\$ -
Sweta Soni	Designer/Drafter	0.0	\$ 101.00	\$ -
Youstina Gaid	Drafter	0.0	\$ 101.00	\$ -
Subtotal OMID Maintenance:				\$ 3,564.00

NEPS Maintenance – Fund 82912, Program 149090, Account 730646 (3.2-3.3-3.4C & ALLOWANCE)

<u>Name</u>	<u>Title</u>	<u>Hrs.</u>	<u>Rate/Hr.</u>	<u>Amount</u>
Raj Vijayendran, PE	Principal Engineer	8.0	\$ 225.75	\$ 1,806.00
Terry Moore	Operations Manager	22.0	\$ 162.00	\$ 3,564.00
Terry Moore	Operations Manager (Overt	0.0	\$ 204.75	\$ -
Daniel Martel	Sr. Project Coordinator	0.0	\$ 152.25	\$ -
Sean Grant	Sr. Project Engineer	0.0	\$ 152.25	\$ -
Travis Ford	Sr. Project Engineer	0.0	\$ 152.25	\$ -
Shailesh Patel	Sr. Project Engineer	0.0	\$ 152.25	\$ -
Darrin Green	Staff Engineer	72.0	\$ 102.00	\$ 7,344.00
Darrin Green	Staff Engineer-(Overtime)	17.0	\$ 153.00	\$ 2,601.00
Anthony Vozza	Staff Engineer	68.0	\$ 102.00	\$ 6,936.00
Anthony Vozza	Staff Engineer-(Overtime)	4.0	\$ 153.00	\$ 612.00
Abhishek Shah	Staff Engineer	0.0	\$ 102.00	\$ -
Sweta Soni	Designer/Drafter	0.0	\$ 105.50	\$ -
Keli Mills	Administrative Assoc.	0.0	\$ 77.48	\$ -

Subtotal: \$ 22,863.00

Maintenance Services (see attached invoices): \$ 1,480.46

Subtotal NEPS Maintenance: \$ 24,343.46

Subtotal Maintenance: \$ 27,907.46

NEXGEN Asset Management Implementation Services – Fund 82912, Program 149090, Account 730646

<u>Name</u>	<u>Title</u>	<u>Hrs.</u>	<u>Rate/Hr.</u>	<u>Amount</u>
Raj Vijayendran, PE	Principal Engineer	0.0	\$ 225.75	\$ -
Terry Moore	Operations Manager	0.0	\$ 162.00	\$ -
Terry Moore	Operations Manager (Overt	0.0	\$ 204.75	\$ -
Sean Grant	Sr. Project Engineer	0.0	\$ 152.25	\$ -
Darrin Green	Staff Engineer	0.0	\$ 102.00	\$ -
Darrin Green	Staff Engineer-(Overtime)	0.0	\$ 153.00	\$ -
Anthony Vozza	Staff Engineer	0.0	\$ 102.00	\$ -
Abhishek Shah	Staff Engineer	0.0	\$ 102.00	\$ -
Brandon Brochue	Designer/Drafter	0.0	\$ 101.00	\$ -

Subtotal Maintenance: \$ -

Task 12.0 - As-Needed Services -

Additional General/Excess Liability Insurance Fee (2024): \$ 38,274.13

TOTAL AMOUNT DUE THIS INVOICE: \$ 92,567.51



MOTOR CITY ELECTRIC TECHNOLOGIES

9440 Grinnell St., Detroit, MI 48213

(313) 921-5300/FAX (313) 923-5310

"AN EQUAL OPPORTUNITY EMPLOYER"

INVOICE

Oakland Macomb Interceptor District (OMID)
 One Public Works Drive, Building 95
 Waterford, MI 48328

**Customer
 PO Number**
 N/A

Job Number	Contract Number	Date Performed	Application	
			Date	Number
926567	0	11/13/2025	11/13/2025	96914

Joel Brown

Item No	Description of Work	Contract Amount	Previous Billings	Current Amount	To Date Completed & Stored	Balance To Finish	Current Retainage
001	SCADA T&M Services	\$317.50	-	\$317.50	\$317.50	-	-
Totals:		\$317.50		\$317.50	\$317.50		
Less Retained:				-			
Invoice Total:				\$317.50			

DSJ 2025/11/17

MCET - NESPS					
82912	6010101	149090	730660	8419	Ch. 21

AS NEEDED ELECTRICAL AND ENGINEERING SUPPORT
 SEE ATTACHED INVOICE SUMMARY AND FIELD REPORT

WORK PERFORMED 11/7/25 & 11/13/25

WO# 1638

ALL CREDIT CARD PAYMENTS WILL INCUR A 2.5% SURCHARGE FEE (\$325.44)

Complete Electrical Construction

"We hereby certify that the articles and services covered by this invoice were produced and performed in compliance with all applicable requirements of Section 6, 7 and 12 of the Fair Labor Standards Act, as amended, and of regulations and orders of the United States Department of Labor issued under Section 14 thereof."

NTH Consultants, Ltd.

 Infrastructure Engineering
and Environmental Services

OMI Drain Drainage District
One Public Works Drive
Building 95 West
Waterford, MI 48328

Invoice # : 640766
Project : 61-210313
Invoice Group : **
Invoice Date : 12/2/2025

Attention: Joel Brown, P.E.

For Professional Services Rendered from 9/20/2025 - 11/21/2025

Consulting Services Regarding Additional OMID Rehabilitation Program 2021 Closeout Services and As-Needed NESPS Maintenance Tasks

Task 01	Contract 3 NESPS Rehab Closeout	\$9,563.00
Task 02	PCI-4 Liner Deterioration Closeout	\$10,939.00
Task 03	Discharge Pipe Coating Rehabilitation	\$27,930.00
Task 04	NESPS Wet Well Sediment Survey	\$19,639.00
	Preliminary Budget Amount	\$68,071.00
	Percent Complete:	96.87%

Analysis of Costs		This Invoice	Cumulative
Direct Salaries		\$ 249.61	\$ 12,683.47
Overhead %	188.00	469.27	23,844.91
Total Regular Labor Expense		718.88	36,528.38
Total Direct Labor		718.88	36,528.38
Profit / Fixed Fee %	12.00	86.27	4,383.41
Direct Expenses Charge		0.00	280.49
Expense Multiplier %	5.00	0.00	14.02
Direct Subcontractor Charge		0.00	23,555.34
Subcontractor/Subconsultant Multiplier %	5.00	0.00	1,177.79
Total Other Direct Charges Reimbursables		0.00	25,027.64
Total Costs:		805.15	65,939.43
Total Due This Invoice		\$ 805.15	\$ 65,939.43



PM Technologies
28294 Beck Road
Wixom, Michigan 48393
800-419-5199
pmtch.org

PM Technologies - NESPS					
82912	6010101	149090	730660	8640	Ch. 21

BILL TO
County Of Oakland
A Michigan Constitutional Corp
Detroit, MI 48234 USA

INVOICE 130373457	INVOICE DATE 11/3/2025
-----------------------------	----------------------------------

JOB ADDRESS
Northeast Sewage Pumping Station - Generator #2 1825kw
11001 East State Fair Avenue
Detroit, MI 48234 USA

Completed Date 11/3/2025
Customer PO #
Payment Term NET 30
Due Date 12/3/2025

DESCRIPTION OF WORK

WO #01600

TASK	DESCRIPTION	QTY	PRICE	TOTAL
Monthly Inspections	Monthly Inspection Perform Secondary Inspection on generator and transfer switch(es). Update on-site maintenance log (as applicable) **excludes live transfer test	1.00	\$350.00	\$350.00

SUB-TOTAL	\$350.00
TOTAL DUE	\$350.00
PAYMENT	\$0.00
BALANCE DUE	\$350.00

Thank you for choosing PM Technologies

DBS 2025/11/20



PM Technologies
28294 Beck Road
Wixom, Michigan 48393
800-419-5199
pmtch.org

PM Technologies - NESPS

82912 6010101 149090 730660 8640 Ch. 21

BILL TO

County Of Oakland
A Michigan Constitutional Corp
Detroit, MI 48234 USA

INVOICE
130380504

INVOICE DATE
11/3/2025

JOB ADDRESS

Northeast Sewage Pumping Station - Generator #1 1825kw
11001 East State Fair Avenue
Detroit, MI 48234 USA

Completed Date 11/3/2025
Customer PO #
Payment Term NET 30
Due Date 12/3/2025

DESCRIPTION OF WORK

WO #01600

TASK	DESCRIPTION	QTY	PRICE	TOTAL
Monthly Inspections	Monthly Inspection Perform Secondary Inspection on generator and transfer switch(es). Update on-site maintenance log (as applicable) **excludes live transfer test	1.00	\$350.00	\$350.00

SUB-TOTAL \$350.00

TOTAL DUE \$350.00
PAYMENT \$0.00

BALANCE DUE \$350.00

Thank you for choosing PM Technologies

DBS 2025/11/20



PM Technologies
28294 Beck Road
Wixom, Michigan 48393
800-419-5199
pmttech.org

PM Technologies - NESPS

82912 6010101 149090 730660 8640 Ch. 21

BILL TO

County Of Oakland
A Michigan Constitutional Corp
Detroit, MI 48234 USA

INVOICE
130380529

INVOICE DATE
11/3/2025

JOB ADDRESS

Northeast Sewage Pumping Station - Generator #3 1825kw
11001 East State Fair Avenue
Detroit, MI 48234 USA

Completed Date 11/3/2025
Customer PO #
Payment Term NET 30
Due Date 12/3/2025

DESCRIPTION OF WORK

WO #01600

TASK	DESCRIPTION	QTY	PRICE	TOTAL
Monthly Inspections	Monthly Inspection Perform Secondary Inspection on generator and transfer switch(es). Update on-site maintenance log (as applicable) **excludes live transfer test	1.00	\$350.00	\$350.00

SUB-TOTAL \$350.00

TOTAL DUE \$350.00
PAYMENT \$0.00

BALANCE DUE \$350.00

Thank you for choosing PM Technologies

DBS 2025/11/20



ROTOR ELECTRIC COMPANY OF MICHIGAN, LLC

9522 Grinnell
Detroit, MI 48213
TEL: 313-891-0331
FAX: 313-891-0511
www.rotorelectric.com

November 11, 2025

Mr. Terry Moore
Sr. Operations Specialist
METCO Services
12835 Stephens Rd
Warren, MI 48089

Re: WO#1607 P2 VFD Shelter Power Loss And P2 VFD Fan Replacement / Invoice#12946

Dear Mr. Moore,

The Rotor Electric Company is pleased to offer this cost breakdown to provide the labor to diagnose the cause of the loss of house power in the P2 VFD shelter and then perform the corrective repairs required to restore power to the VFD shelter. The cause of the power loss was a dead short in one of the VFD cooling fan motors. This motor was replaced using a repair stock motor. Every P2 VFD fan is now functional.

Labor Summary

Field Report G719707-00557

Foreman: 4 Hours @\$150.00	\$600.00
Journeyman: 4 Hours @ \$137.00	\$548.00
Project Manager: 2 Hours @ 167.75	\$335.50

Subtotal labor: \$1,483.50

Field Report G719707-00563

Project Manager: 2 Hours @ 167.75	\$335.50
Testing Technician: 16 Hours @\$167.75	\$2,684.00

Subtotal labor: \$3,019.50

Invoice total \$4,503.00

DBS 2025/11/17

Sincerely,

Norman M. Stangis

Norman M. Stangis B.S.E.E.

Rotor Electric - NESPS					
82912	6010101	149090	730660	8629	Ch.21



ROTOR ELECTRIC COMPANY OF MICHIGAN, LLC

9522 Grinnell
Detroit, MI 48213
TEL: 313-891-0331
FAX: 313-891-0511
www.rotorelectric.com

November 11, 2025

Mr. Terry Moore
Sr. Operations Specialist
METCO Services
12835 Stephens Rd
Warren, MI 48089

Re: WO#1610 CS6 Power Loss / Invoice#12947

Dear Mr. Moore,

The Rotor Electric Company is pleased to offer this cost breakdown to provide the labor to diagnose the cause of the loss of equipment shelter power at the CS6 structure (contractor damage to DTE cable)..

Labor Summary

Field Report G719707-00558

Project Manager: 4 Hours @ 167.75	\$671.00
Testing Technician: 8 Hours @\$167.75	\$1,342.00

Invoice total

DBJ 2025/11/17 **\$2,013.00**

Sincerely,

Norman M. Stangis

Norman M. Stangis B.S.E.E.

Rotor Electric - NESPS					
82912	6010101	149090	730660	8629	Ch.21



ROTOR ELECTRIC COMPANY OF MICHIGAN, LLC

9522 Grinnell
Detroit, MI 48213
TEL: 313-891-0331
FAX: 313-891-0511
www.rotorelectric.com

November 11, 2025

Mr. Terry Moore
Sr. Operations Specialist
METCO Services
12835 Stephens Rd
Warren, MI 48089

Re: WO#1613 P4 VFD Fan Motor Fault / Invoice#12948

Dear Mr. Moore,

The Rotor Electric Company is pleased to offer this cost breakdown to provide the labor to diagnose the cause of the fan motor fault on the P4 VFD. Testing on the fan motor and wiring confirmed that there was not an issue with the motor. The thermal overload ratings are closer to the fan current draw than expected. Please note that this VFD is equipped with redundant cooling fans and can be safely operated with only a single fan bank.

Labor Summary

Field Report G719707-00564

Project Manager: 4 Hours @ 167.75	\$671.00
Testing Technician: 8 Hours @\$167.75	\$1,342.00

Invoice total	\$2,013.00
----------------------	-------------------

Sincerely,

Norman M. Stangis

Norman M. Stangis B.S.E.E.

DBS 2025/11/17

Rotor Electric - NESPS					
82912	6010101	149090	730660	8629	Ch.21



ROTOR ELECTRIC COMPANY OF MICHIGAN, LLC

9522 Grinnell
Detroit, MI 48213
TEL: 313-891-0331
FAX: 313-891-0511
www.rotorelectric.com

November 11, 2025

Mr. Terry Moore
Sr. Operations Specialist
METCO Services
12835 Stephens Rd
Warren, MI 48089

Re: WO#1613 P4 VFD Fan Motor Fault / Invoice#12949

Dear Mr. Moore,

The Rotor Electric Company is pleased to offer this cost breakdown to provide the labor to perform the switching required to return pump P3 to service.

Labor Summary

Field Report G719707-00561

Project Manager: 2 Hours @ 167.75	\$335.50
Testing Technician: 4 Hours @\$167.75	\$671.00

Invoice total	\$1,006.50
----------------------	-------------------

Sincerely,

Norman M. Stangis

Norman M. Stangis B.S.E.E.

DSS 2025/11/17

Rotor Electric - NESPS					
82912	6010101	149090	730660	8629	Ch.21



ROTOR ELECTRIC COMPANY OF MICHIGAN, LLC

9522 Grinnell
Detroit, MI 48213
TEL: 313-891-0331
FAX: 313-891-0511
www.rotorelectric.com

November 11, 2025

Mr. Terry Moore
Sr. Operations Specialist
METCO Services
12835 Stephens Rd
Warren, MI 48089

Re: WO#1633 P1 Trip Event 11-1-25 / Invoice#12950

Dear Mr. Moore,

The Rotor Electric Company is pleased to offer this cost breakdown to provide the labor to try and identify the cause of the 11-3-2025 P1 trip event and confirm pump can be returned to service.

Labor Summary

Field Report G719707-00562

Project Manager: 2 Hours @ 167.75 \$335.50
Testing Technician: 6 Hours @\$167.75 **\$1,006.50**

Invoice total

DBS 2025/11/17

\$1,342.00

Sincerely,

Norman M. Stangis

Norman M. Stangis B.S.E.E.

Rotor Electric - NESPS					
82912	6010101	149090	730660	8629	Ch.21



Applied Science, Inc.

21455 Melrose Ave. Bldg R Suite 12 Southfield, MI 48075
Phone: (313) 567-3990
www.asi-eng.com

11/14/2025

Project Invoice #78 (ASI Inv. #9453)
WRC Coding String: 84917-6010101-149015-730639-PRJ13309-ENGCON-8420-Ch.21

Joel Brown, P.E.
Civil Engineer III
Oakland County Water Resources Commissioner's Office
One Public Works Drive, Building 95 West
Waterford, MI 48328

Re: Northeast Sanitary Pump Station
Contract #5470
(ASI Job No. 1815)

Invoice Period: 8/31/25-11/1/25

Task No.	Task Description	Total This Invoice
1	Transition & Basis of Design	
	Total:	\$ -
	Subconsultants:	
	ASI Markup 5%:	\$ -
	Total:	\$ -

Task No.	Task Description	Total This Invoice
2	Design Services for Pump & Electrical Upgrades	
	Total:	\$ -
	Subconsultants:	
	ASI Markup 5%:	\$ -
	Total Due This Invoice:	\$ -

Task No.	Task Description	Total This Invoice
3	Additional Special Services	
	Total:	\$ -
	Subconsultants:	
	ASI Markup 5%:	\$ -
	Total Due This Invoice:	\$ -

Task No.	Task Description	Total This Invoice
5	Construction Services	
	Total:	\$ 24,720.00
	Subconsultants:	
	NTH Consultants	\$ 28,631.64
	Metco Services	\$ 12,348.00
	FK Engineering:	\$ 8,621.25
	ASI Markup 5%:	\$ 2,480.04
	Total Due This Invoice:	\$ 76,800.93

Task No.	Task Description	Total This Invoice
6	Control Structure Rehab	
	Total:	\$ -
	Subconsultants:	
	NTH Consultants	\$ -
	ASI Markup 5%:	\$ -
	Direct Expenses:	\$ -
	Total Due This Invoice:	\$ -

Summary

Total Due This Invoice Tasks #1-6:	\$ 76,800.93
Amount Invoiced to Date Tasks #1-6:	\$ 6,440,418.32
Total Due This Invoice MCC Incident (separate invoice):	\$ -
Amount Invoiced to date for MCC Incident (separate invoice):	\$ 68,336.23
Total Due This Invoice Pump Issues (separate invoice):	\$ -
Amount Invoiced to date for Pump Issues (separate invoice):	\$ 33,824.00
Total Invoiced To-Date:	\$ 6,542,578.55
Original Contract Task Total:	\$ 4,198,380.00
Additional Budget-Task 5:	\$ 284,076.60
Additional Budget-Task 5a:	\$ 1,513,301.00
Additional Budget-Task 5b:	\$ 510,144.00
Additional Budget-Task 6:	\$ 220,326.00
Current Contract Task Total:	\$ 6,726,227.60
Amount Remaining:	\$ 183,649.05



Steven Korth

84917-6010101-149015-731073-1-3309 -
LEGAL - Ch. 21 - CON9318

Oct. 21, 2025

Oakland County Water Resources Commissioner, MI
One Public Works Drive
Waterford, MI 48328-1907
WRClegalinvoices@oakgov.com
toddm@oakgov.com

Invoice: 1648638
Date: 10/14/2025
Client: 030164
Matter: 0463149

Matter Name: Construction Dispute - Walsh Construction

LEGAL SERVICES RENDERED AND COSTS ADVANCED THROUGH SEPTEMBER 30, 2025

Total Fees:	\$	2,135.00
Total Due This Invoice:	\$	2,135.00

MK 10/21/25

FOR ACH/WIRE REMITTANCES:
PNC Bank, N.A.
500 First Ave.
Pittsburgh, PA 15219
ABA ACH: 041000124
WIRE: 041000124
Account: 4130223462
Account Name: Clark Hill PLC
SWIFTCODE: PNCCUS33

PLEASE REMIT TO:
Clark Hill PLC
PO Box 641858
Pittsburgh, PA 15264-1858

Fed ID: 38-0425840

Scan to Pay
clarkhill.com/invpayments



Please forward remittance details to: remit-pmts@clarkhill.com
For assistance making a payment please call (313) 965-8290



84917-6010101-149015-731073-1-3309 -
LEGAL - Ch. 21 - CON9318

Oakland County Water Resources Commissioner, MI
One Public Works Drive
Waterford, MI 48328-1907
WRClegalinvoices@oakgov.com
toddm@oakgov.com

Invoice: 1657174
Date: 11/08/2025
Client: 030164
Matter: 0463149

Matter Name: Construction Dispute - Walsh Construction

LEGAL SERVICES RENDERED AND COSTS ADVANCED THROUGH OCTOBER 31, 2025

Total Fees:	\$	3,710.00
Total Due This Invoice:	\$	3,710.00

MK 11/20/25

FOR ACH/WIRE REMITTANCES:
PNC Bank, N.A.
500 First Ave.
Pittsburgh, PA 15219
ABA ACH: 041000124
WIRE: 041000124
Account: 4130223462
Account Name: Clark Hill PLC
SWIFTCODE: PNCCUS33

PLEASE REMIT TO:
Clark Hill PLC
PO Box 641858
Pittsburgh, PA 15264-1858

Fed ID: 38-0425840

Scan to Pay
clarkhill.com/invpayments



Please forward remittance details to: remit-pmts@clarkhill.com
For assistance making a payment please call (313) 965-8290



INVOICE

Invoice No.: C6A19900-31
 Invoice Date: 12/3/2025
 Jacobs Project No.: C6A19900
 Services From: 10/25/2025
 Services Through: 11/21/2025

Jacobs Consultants, Inc.

Oakland-Macomb Interceptor Drain Drainage District
 c/o Oakland County Water Resources Commissioner's Office
 One Public Works Drive
 Building 95 West
 Waterford, Michigan 48328

Attn.: Ms. Jen Cook, P.E.

Project Description: Odor and Corrosion Control Systems within the OMID

Task Number	Task Description	Task Budget	Previously Invoiced	Current Invoice	Project to Date	Remaining Budget
1	Additional Investigation/Modeling	\$226,151.90	\$225,936.71	\$0.00	\$225,936.71	\$215.19
2	Basis of Design	\$122,605.02	\$122,303.64	\$0.00	\$122,303.64	\$301.38
3	ST-S-3 Vapor-Phase Treatment System - Subtask 3.1 - Design	\$276,371.00	\$276,367.83	\$0.00	\$276,367.83	\$3.17
	ST-S-3 Vapor-Phase Treatment System - Subtask 3.2 - Bidding	\$17,154.74	\$17,150.52	\$0.00	\$17,150.52	\$4.22
4	CS-6 Pump Station Vapor-Phase System - Subtask 4.1 - Design	\$191,218.29	\$96,755.18	\$0.00	\$96,755.18	\$94,463.11
	CS-6 Pump Station - Vapor-Phase System Subtask 4.2 - Bidding	\$15,612.91	\$15,604.83	\$0.00	\$15,604.83	\$8.08
5	CS-8 and ST-S-1 Local Odor Control - Subtask 5.1 - Design	\$80,199.91	\$80,194.04	\$0.00	\$80,194.04	\$5.87
	CS-8 and ST-S-1 Local Odor Control - Subtask 5.2 - Bidding	\$12,829.09	\$12,784.70	\$0.00	\$12,784.70	\$44.38
6	Design Emergency Relief Valves for CS-9 High Pressures	\$21,081.00	\$21,071.61	\$0.00	\$21,071.61	\$9.39
7	Construction Ventilation Coordination	\$11,194.00	\$11,117.15	\$0.00	\$11,117.15	\$76.85
8	OMIDDD Progress Meeting Correction	\$32,868.00	\$32,865.66	\$0.00	\$32,865.66	\$2.34
9	Monthly Design Coordination Meetings Correction	\$46,767.00	\$46,735.41	\$0.00	\$46,735.41	\$31.59
10	Construction Administration	\$860,372.00	\$462,511.77	\$42,446.91	\$504,958.68	\$355,413.32
11	Resident Project Engineer	\$170,948.00	\$50,230.15	\$11,031.57	\$61,261.72	\$109,686.28
12	Post-Construction Services	\$144,988.00	\$0.00	\$0.00	\$0.00	\$144,988.00
10a	Reimbursement of Permitting Fees	\$11,943.00	\$11,673.12	\$0.00	\$11,673.12	\$269.88
13	Review Existing Available Information	\$4,425.00	\$4,423.84	\$0.00	\$4,423.84	\$1.16
14	Conduct Site Investigation at CS-9 and Adjacent Neighborhood	\$13,450.00	\$13,449.44	\$0.00	\$13,449.44	\$0.56
15	Collect Additional OMID H2S and Air Pressure Data	\$0.00	\$0.00	\$0.00	\$0.00	\$0.00
16	Determine Approximate Sizing and Prepare Conceptual Layout at CS-9	\$0.00	\$0.00	\$0.00	\$0.00	\$0.00
17	Collect Additional OMID CS-5 and CS-9 H2S and Air Pressure Data	\$24,884.00	\$19,225.27	\$0.00	\$19,225.27	\$5,658.73
18	Conduct Site Investigation and Collect Additional H2S and Air Pressure Data within the NI-EA Near Meldrum and Mt. Elliott	\$22,857.00	\$0.00	\$0.00	\$0.00	\$22,857.00
19	Confirm NESPS Biotrickling Filter Zone of Influence	\$22,998.00	\$0.00	\$0.00	\$0.00	\$22,998.00
20	Verify Sizing and Prepare Plan Sketch of Active Odor/Corrosion Control System near CS-6 Site	\$19,244.00	\$0.00	\$0.00	\$0.00	\$19,244.00
21	Material Testing Allowance	\$25,000.00	\$22,258.55	\$0.00	\$22,258.55	\$2,741.45
	Total	\$2,375,161.86	\$1,542,659.42	\$53,478.48	\$1,596,137.90	\$779,023.95

Previously Invoiced: \$1,542,659.42
 Total Due This Invoice: \$53,478.48
 Total Invoiced To Date: \$1,596,137.90
 Total Budget: \$2,375,161.86
 Remaining Budget: \$779,023.95

Outstanding Invoices					
Date	Invoice No.	Invoiced Amount	Paid Date	Paid Amount	Amount Outstanding

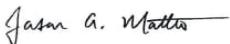
Signed: 
 Jason A. Matteo, P.E.
 Project Manager

Please remit payment electronically to:
 Beneficiary Bank: Bank of America
 Account Name: Jacobs Consultants, Inc.
 Transit for ACH: 111000012
 Transit for Wires: 026009593
 Account No.: 4451457732



NTH Consultants, Ltd.
 Infrastructure Engineering
 and Environmental Services

OMI Drain Drainage District
One Public Works Drive
Building 95 West
Waterford, MI 48328

Invoice # : 640770
Project : 23001693
Invoice Group : **
Invoice Date : 12/2/2025

Attention: Jen Cook, P.E.

For Professional Services Rendered from 10/25/2025 - 11/21/2025

Provide Engineering and Consulting Services regarding OMID PCI-18 and PCI-19 Rehabilitation Project CCA; D-458 & D-463

Task 01	Contract 2 CCA Services	\$1,907,063.00
	Preliminary Budget Amount	\$1,907,063.00
	Percent Complete:	98.32%

Analysis of Costs	This Invoice	Cumulative
Direct Salaries	11,067.73	\$ 387,433.83
Overhead %	188.00 20,807.33	728,375.58
Total Regular Labor Expense	31,875.06	1,115,809.41
Total Direct Labor	31,875.06	1,115,809.41
Profit / Fixed Fee %	12.00 3,825.01	133,897.13
Direct Expenses Charge	16,761.74	80,826.28
Expense Multiplier %	5.00 838.09	4,041.23
Direct Subcontractor Charge	15,079.35	509,931.46
Subcontractor/Subconsultant Multiplier %	6.00 904.76	30,595.97
Total Other Direct Charges Reimbursables	33,583.94	625,394.94
Total Costs:	69,284.01	1,875,101.48
Total Due This Invoice	\$ 69,284.01	\$ 1,875,101.48



Oakland County Water Resources Commissioner
Attn: Joel Brown
One Public Works Drive
Building 95-West
Waterford 48328

September 16, 2025
Invoice No: 03559.01 - 63

Project 03559.01 Oakland-Macomb Interceptor Drainage 2020

Professional Services from August 1, 2025 to August 31, 2025

Task	1.0	Oakland-Macomb Interceptor Drainage 2020
Sub Task	1.1	NESPS

Professional Personnel

	Hours	Rate	Amount
Zann, John	32.00	117.84	3,770.88
Totals	32.00		3,770.88
Total Labor			3,770.88

Additional Fees

Overhead 149.10%	149.10 % of 3,770.88	5,622.38
Profit 10%	10.00 % of 9,393.26	939.33
Total Additional Fees		6,561.71

Total this Sub Task \$10,332.59

Sub Task	1.3	NI-EA Contract No. 2
----------	-----	----------------------

Professional Personnel

	Hours	Rate	Amount
Zann, John	14.00	117.84	1,649.76
Totals	14.00		1,649.76
Total Labor			1,649.76

Additional Fees

Overhead 149.10%	149.10 % of 1,649.76	2,459.79
Profit 10%	10.00 % of 4,109.55	410.96
Total Additional Fees		2,870.75

Total this Sub Task \$4,520.51

Total this Task \$14,853.10

Total this Invoice \$14,853.10

Please remit payment to PMA CONSULTANTS LLC, PO BOX 675234, DETROIT, MI 48267-5234. Please direct any questions regarding this invoice to Samantha Zeisler, Project Administrator, at 734-418-7897 or szeisler@pmaconsultants.com



Oakland County Water Resources Commissioner
Attn: Joel Brown
One Public Works Drive
Building 95-West
Waterford 48328

November 10, 2025
Invoice No: 03559.01 - 65

Project 03559.01 Oakland-Macomb Interceptor Drainage 2020

Professional Services from October 1, 2025 to October 31, 2025

Task 1.0 Oakland-Macomb Interceptor Drainage 2020
Sub Task 1.1 NESPS

Professional Personnel

	Hours	Rate	Amount	
Zann, John	30.00	117.84	3,535.20	
Totals	30.00		3,535.20	
Total Labor				3,535.20

Additional Fees

Overhead 149.10%	149.10 % of 3,535.20	5,270.98	
Profit 10%	10.00 % of 8,806.18	880.62	
Total Additional Fees		6,151.60	6,151.60

Total this Sub Task \$9,686.80

Sub Task 1.3 NI-EA Contract No. 2

Professional Personnel

	Hours	Rate	Amount	
Zann, John	24.00	117.84	2,828.16	
Totals	24.00		2,828.16	
Total Labor				2,828.16

Additional Fees

Overhead 149.10%	149.10 % of 2,828.16	4,216.79	
Profit 10%	10.00 % of 7,044.95	704.50	
Total Additional Fees		4,921.29	4,921.29

Total this Sub Task \$7,749.45

Total this Task \$17,436.25

Total this Invoice \$17,436.25

Please remit payment to PMA CONSULTANTS LLC, PO BOX 675234, DETROIT, MI 48267-5234. Please direct any questions regarding this invoice to Samantha Zeisler, Project Administrator, at 734-418-7897 or szeisler@pmaconsultants.com

Walsh Construction II, LLC

3031 West Grand Blvd.
Suite 640
Detroit, MI 48234
Attn: Daniel Nadeau
(313) 456-6505
dnadeau@walshgroup.com

Invoice Number: **220008-970500**
Invoice Date: **12/01/2025**
Due Date: **12/29/2025**

BILL TO:

Joel Brown, P.E.
Chief Engineer - Construction Projects Unit
One Public Works Drive
Waterford MI 48328
brownjt@oakgov.com
M: 248-410-4908

DESCRIPTION	AMOUNT
Arc Flash Insurance Payment Contractor General Conditions	\$2,260,678
Insurance Deductible	(\$25,000)
Claim Preparation Fee	\$35,112.5
14-Day Waiting period Contractor Portion	(\$133,375)

TOTAL \$2,137,215.50

This is the invoice for the full and final Arc Flash Payment concluding the Walsh Construction insurance claim for the incident which occurred August 23rd, 2022.

Engle Martin cost detail attached.

Agenda Item No. 11

Other Business

Agenda Item No. 12

Adjourn