

SEE STANDARD MANHOLE DRAWING FOR OTHER MANHOLE DETAILS.

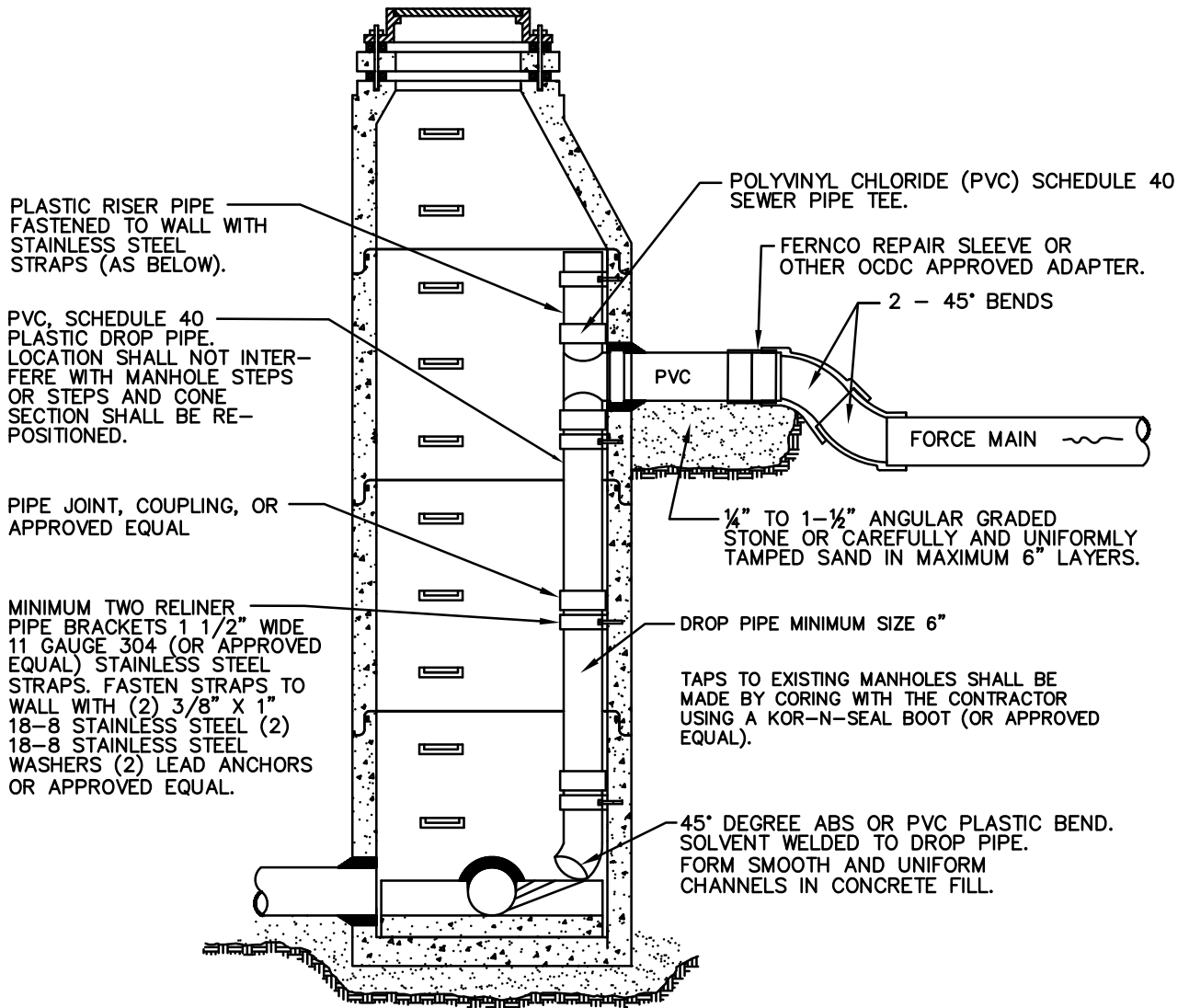

1 1/4" - 20" FORCE MAIN INTERIOR DROP CONNECTION

NOTE: TO BE USED ONLY WHERE SPECIFICALLY AUTHORIZED AND NOT IN ANY MANHOLE IN WHICH AN INTERIOR DROP CONNECTION ALREADY EXISTS. TYPICAL DROP PIPE DIAMETER IS ONE SIZE SMALLER THAN FORCEMAIN DIAMETER.

REVISION BLOCK

Rev. No.:	Rev. By:	Rev. Date:	Description:
1	Iz	03/08/03	ADDED NEW TITLE BLOCK
2	Iz	11/03/05	ADDED PROPOSED CONNECTION
3	DS	01/31/07	DROP PIPE SIZE
4			



FORCE MAIN INTERIOR DROP CONNECTION

ONE PUBLIC WORKS DRIVE, BLDG 95 WEST
WATERFORD, MICHIGAN
48328-1907

ORIG. DATE: 07/24/01
SCALE: NONE

SHEET:
1 of 1